

Einbauanleitung Elektrosatz
Anhängervorrichtung mit 13-P Steckdose
lt. DIN/ISO Norm 11446

Instructions de montage du faisceau
électrique pour crochet d'attelage
conforme à la norme
DIN/ISO 11446 prise 13-P

Fitting instructions electric wiringkit
towbar with 13-P socket up to
DIN/ISO norm 11446

Montage-handleiding elektrokabelset voor
trekhaak met 13-P contactdoos
vlg. DIN/ISO norm 11446

Instrucciones de montaje de juego de cables
eléctricos para gancho de remolque con caja de
conexiones 13-P según norma DIN/ISO 11446

Istruzioni di montaggio di set di cavi elettrici per
gancio da traino con zoccolo a 13-P conforme alla
norma DIN/ISO 11446

Monteringsanvisningar elkabelsats för dragkrok
med 13-P kontaktdosa enligt DIN/ISO norm 11446

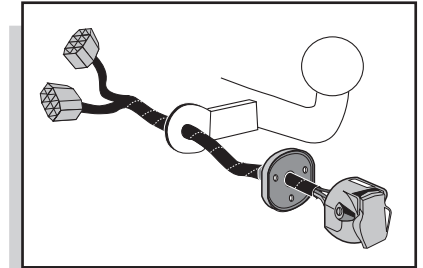

OPEL MERIVA 2003-

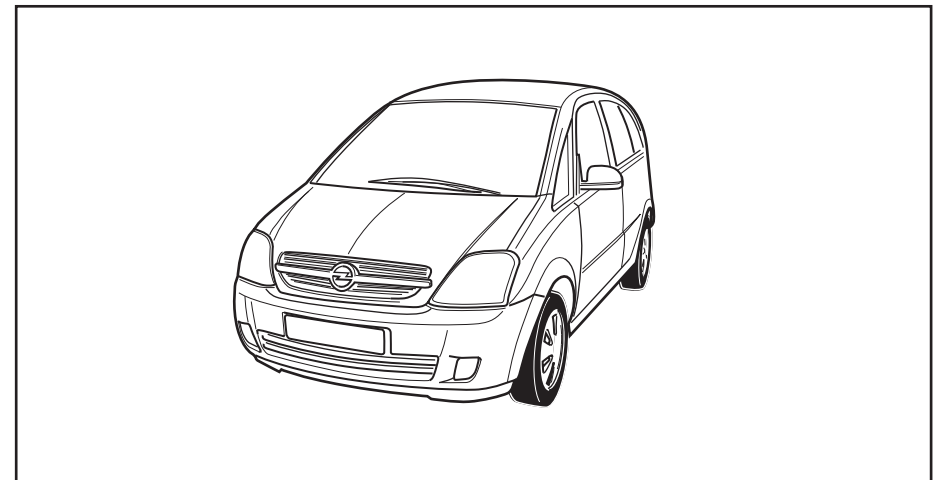

Bestel Nr.: OP-028-DL

*Teilliste *Liste de pieces *Part list *Onderdelenlijst
*Lista de componentes *Elenco componenti *Dellista

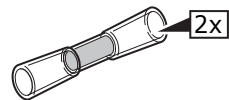
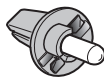
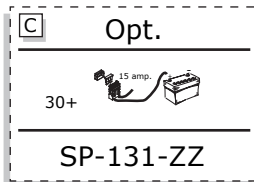
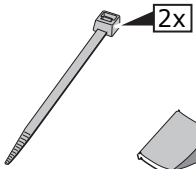
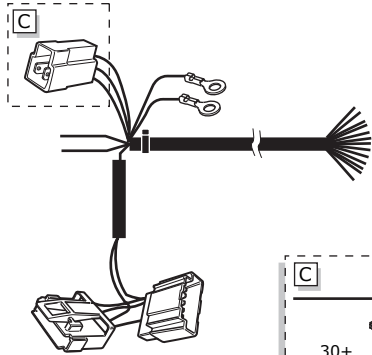
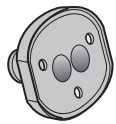
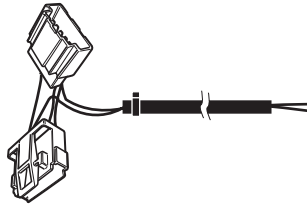
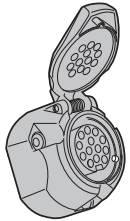
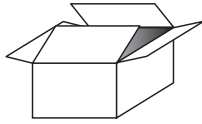

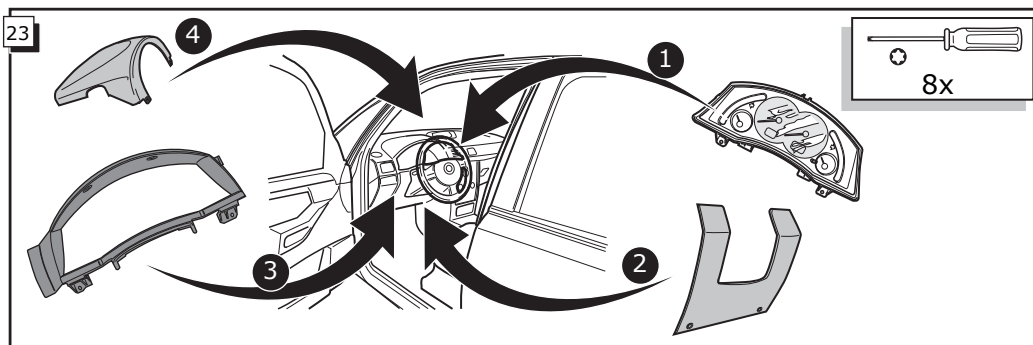
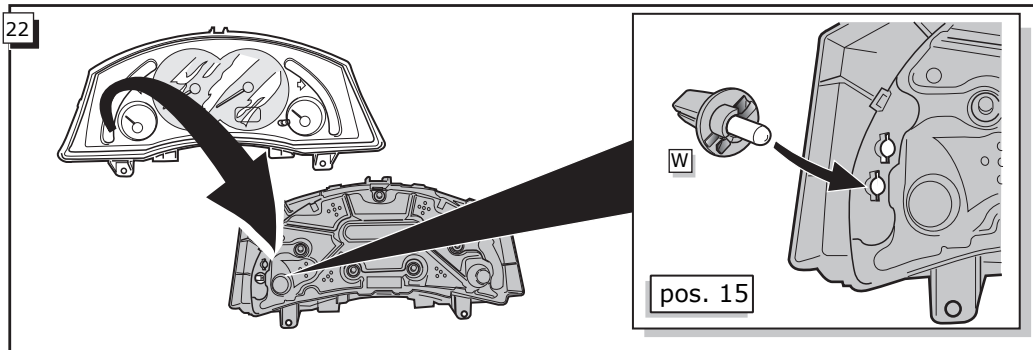
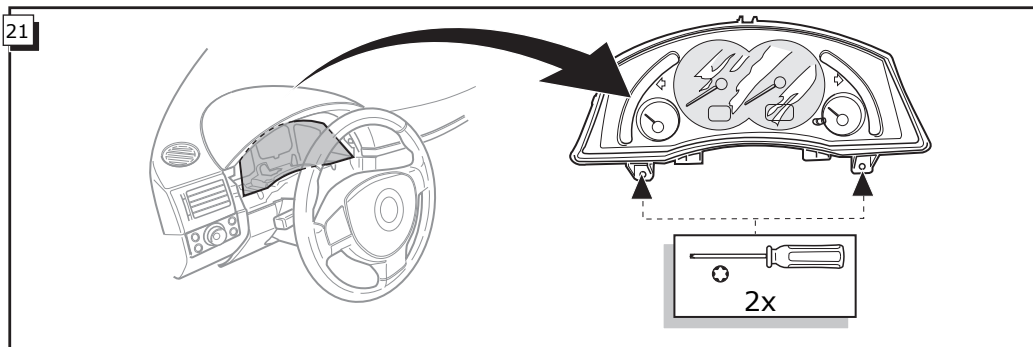
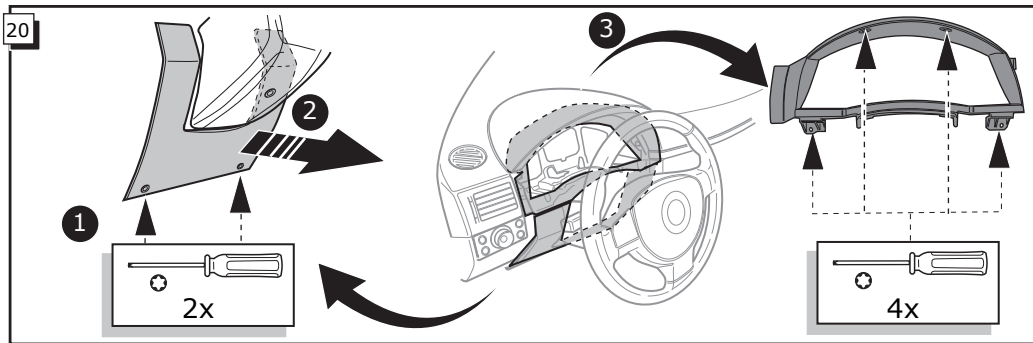

INFO

- Wir weisen ausdrücklich darauf hin, dass eine unsachgemäße und nicht in einer Fachwerkstätte durchgeführte Montage einen Verzicht auf die Geltendmachung jeglicher Art insbesondere auch aus dem Titel des Produkthaftpflichtrechtes bewirkt.
- Technische Änderungen vorbehalten.
- Belastung nur tabellgemäß auf dem Anhänger verwenden, siehe Seite 4.

DU

- Il est expressément prévu qu' on ne saurait se prévaloir d'un quelconque préjudice contractuel ou réhibitoire si le montage avait été fait en dépit des dites instructions ou dans un garage ne disposant pas des équipements adéquats.
- Sous réserve de modifications techniques.
- Ne excédez pas la charge maximale, indiquée dans le tableau sur page 4.

FR

- We would expressly point out that any improper assembly which is not carried out in a specialist workshop will result in the renunciation of the enforcement of compensation claims of any kind, in particular those arising by virtue of the product liability law.
- Subject to alteration without notice.
- Only use maximum charge according to connection table on towed vehicle, see page 4.

GB

- Wij wijzen er met nadruk op, dat ondeskundige en niet door een vakkundige werkplaats uitgevoerde montage tot gevolg heeft dat daardoor ieder recht op schadevergoeding, ook op wettelijke aansprakelijkheid inzake producten, vervalt.
- Technische wijzigingen voorbehouden.
- Gebruik alleen belasting volgens aansluittabel op het getrokken voertuig, zie pagina 4.

NL

- El montaje inapropiado y efectuado por personal no cualificado originará la pérdida de todo derecho a indemnización o la expiración de toda responsabilidad civil con respecto al producto.
- Nos reservamos el derecho a efectuar modificaciones técnicas.
- Utilice sólo cargas de acuerdo a la tabla de conexión del vehículo remolcado (ver página 4).

ES

- Sottolineiamo espressamente che un montaggio inadeguato ed eseguito da un'officina non specializzata ha come conseguenza il decadere di qualsiasi diritto al risarcimento danni, nonché alla responsabilità legale relativa ai prodotti.
- Ci si riserva il diritto di apportare modifiche tecniche.
- Utilizzare esclusivamente un carico conforme alla tabella degli allacci relativa al veicolo in questione, cfr. pagina 4.

IT

- Vi påpekar med eftertryck att all rätt till skadeersättning och all laglig ansvarighet förfaller om monteringen inte har utförts på rätt sätt och av en professionell verkstad.
- Tekniska ändringar förbehålles.
- Använd endast belastning enligt anslutningstabellen på det dragna fordonet, se sid. 4.

SE

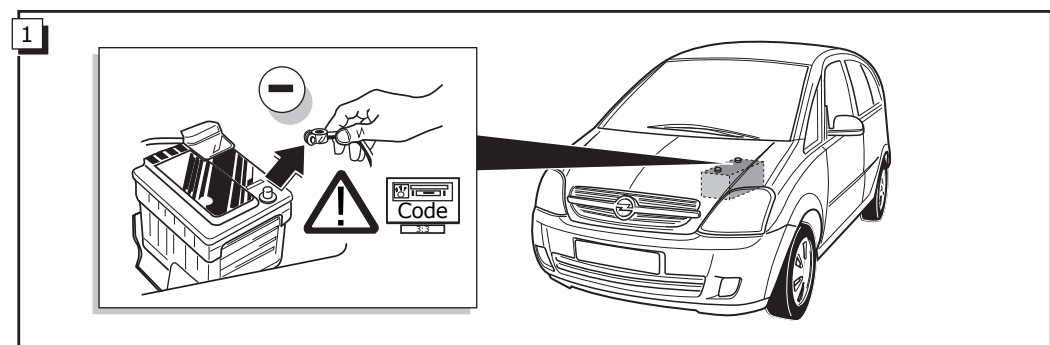

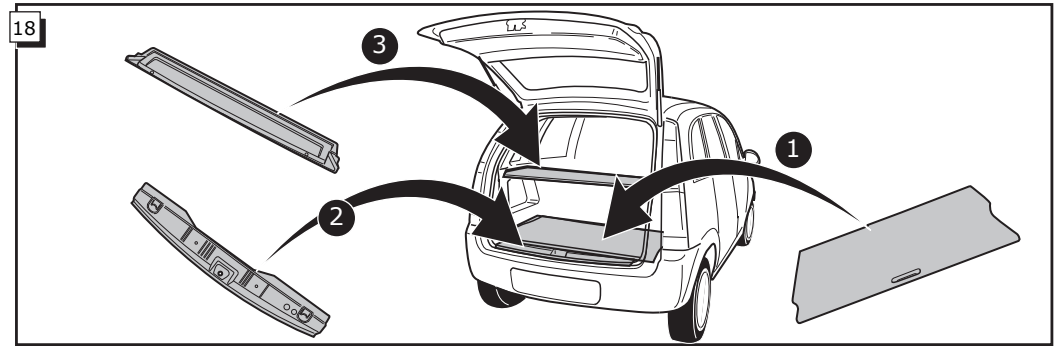
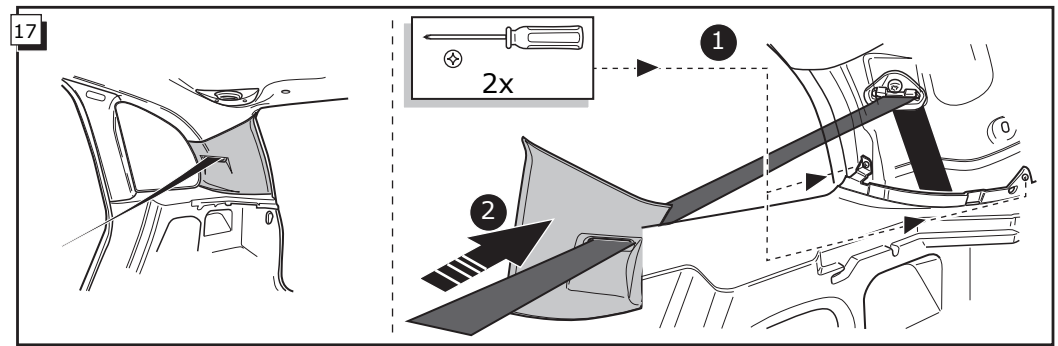
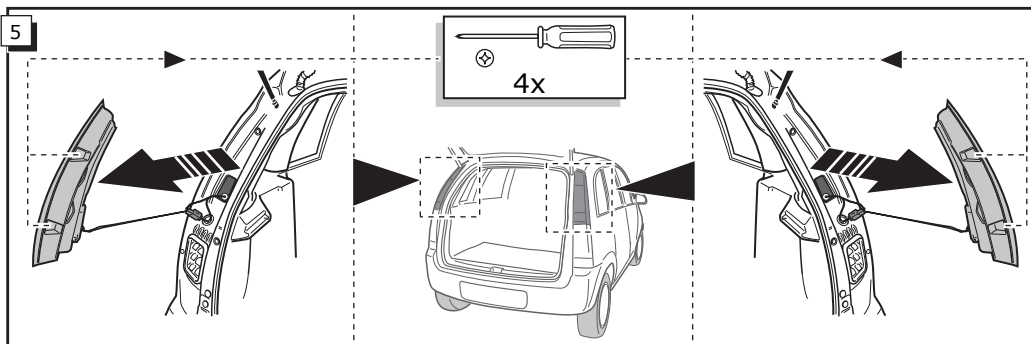
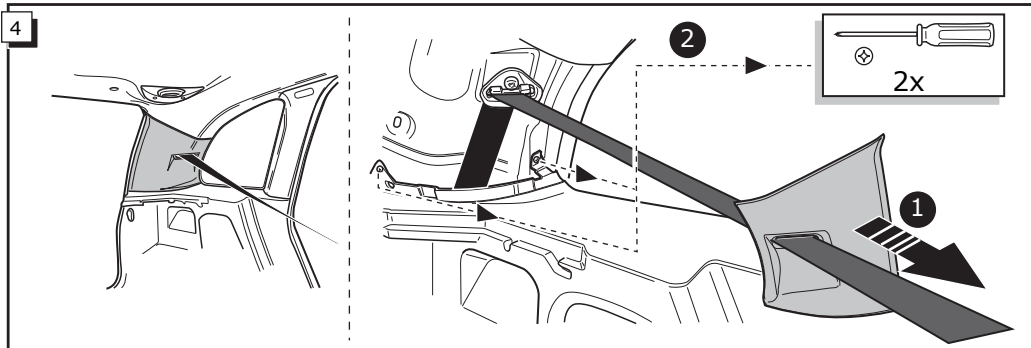
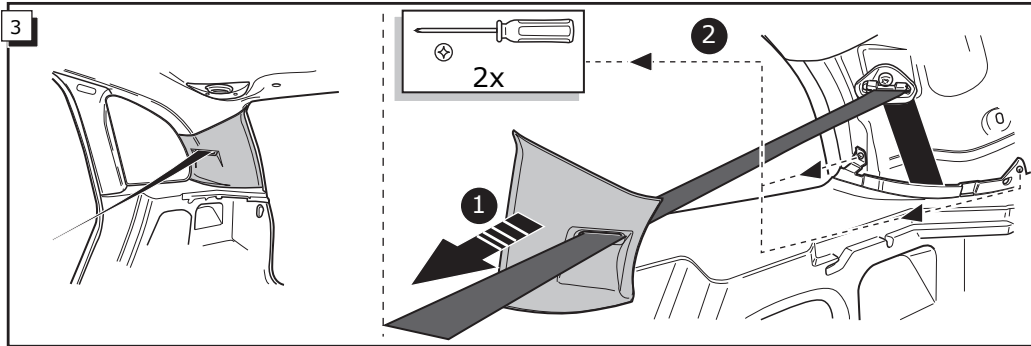
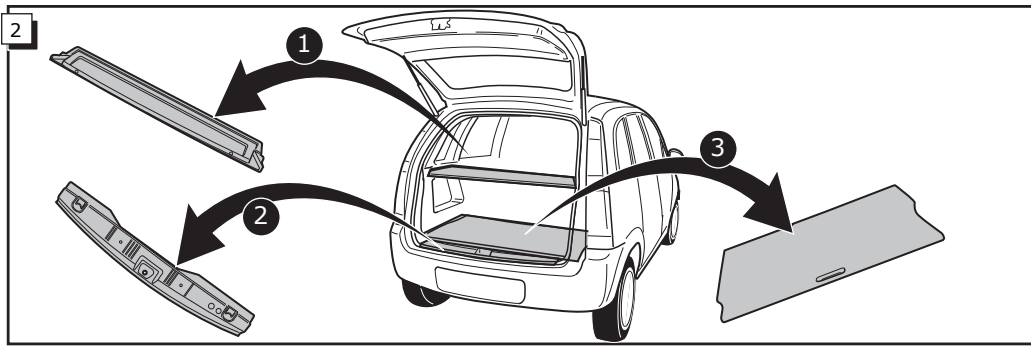

INFO

Fig. 19 bis Fig. 23 nur wenn C2 gewünscht ist!
 Fig. 19 à Fig. 23 seulement quand le C2 est desire!
 Fig. 19 up to Fig. 23 only if C2 is necessary!
 Fig. 19 t/m Fig. 23 alleen indien C2 gewenst is!
 Fig. 19 y Fig. 23 solamente el C2 necesario!
 Fig. 19 e Fig. 23 solamente el C2 necessario!

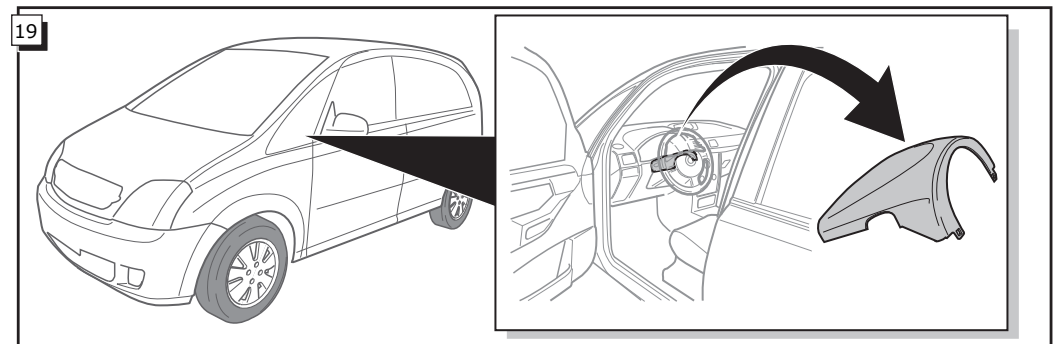

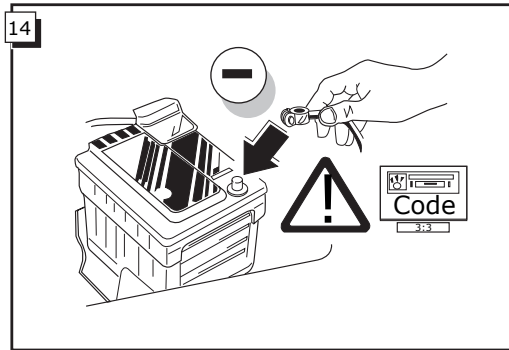
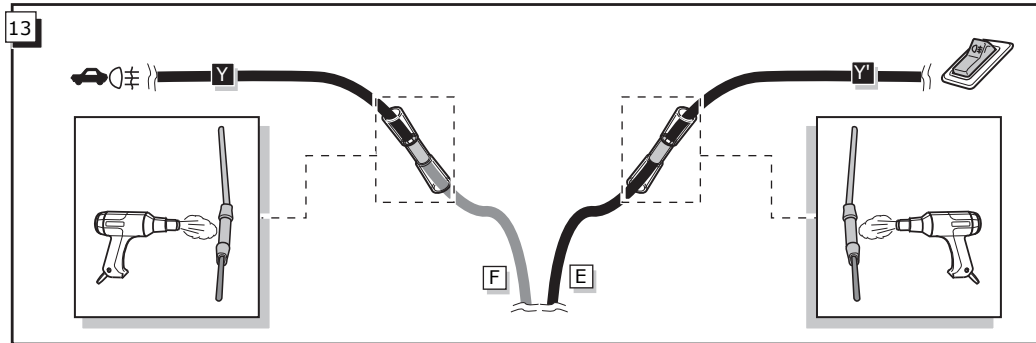
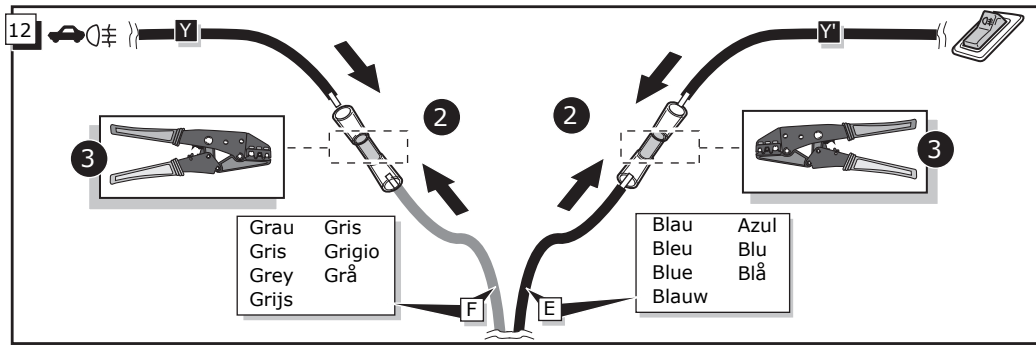

15

FUNKTIONEN KONTROLLIEREN !
CONTRÔLER LES FONCTIONS !
CHECK FUNCTIONS !
CONTROLEER FUNCTIES !
PROBAR FUNCIONES !
VERIFICARE LE FUNZIONI !
MÄTNING FUNKTIONER !

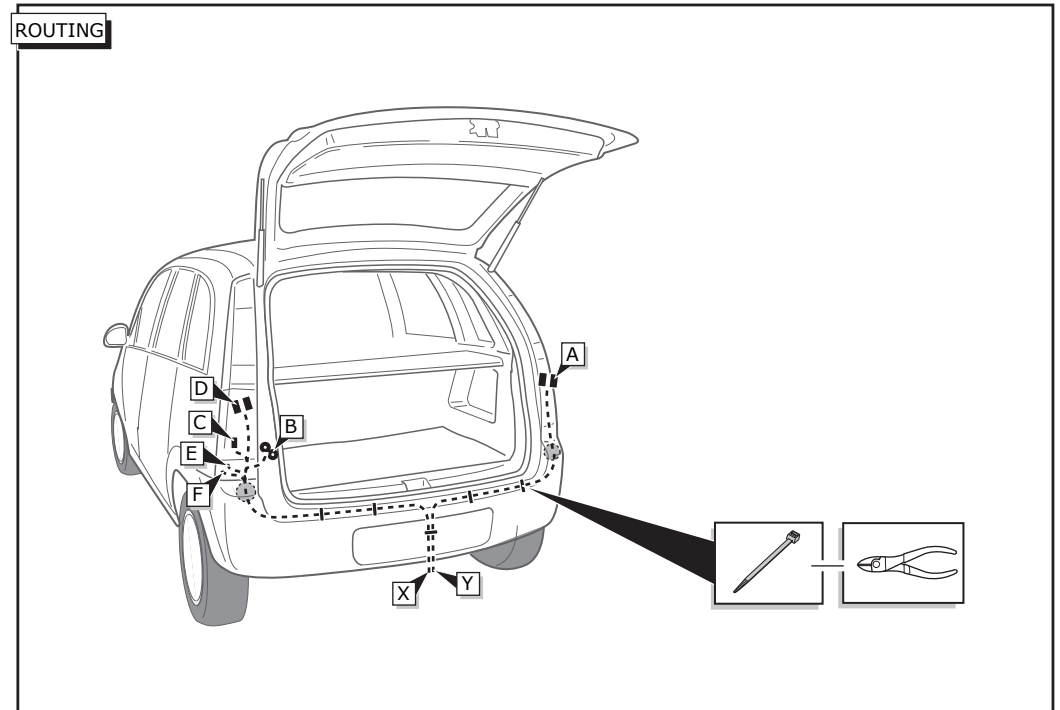
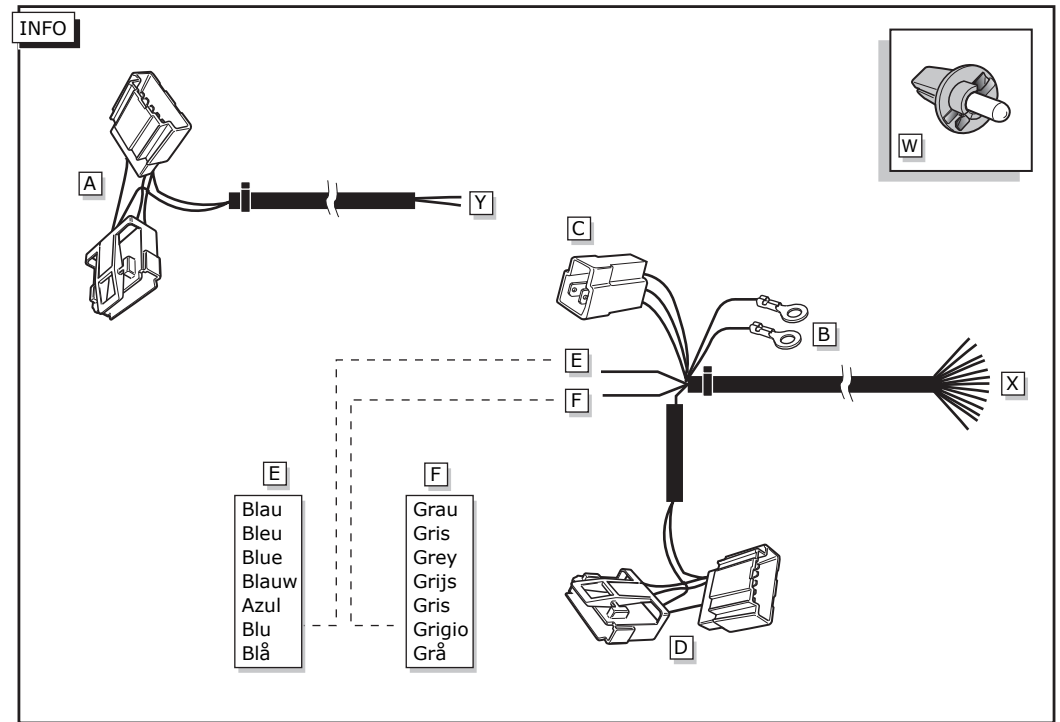
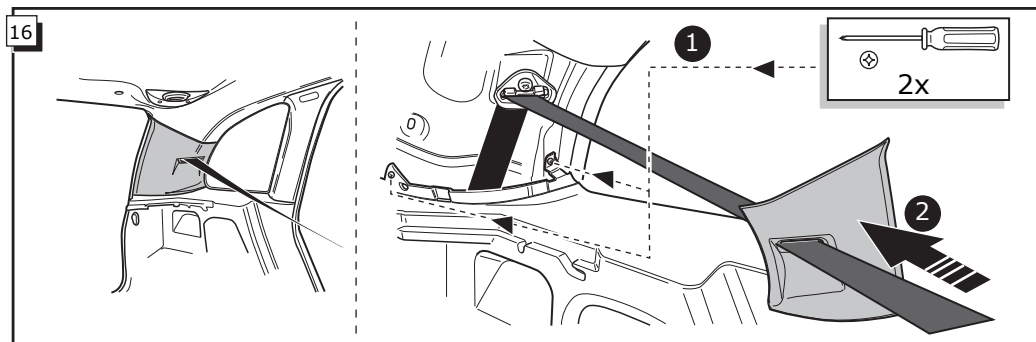

6

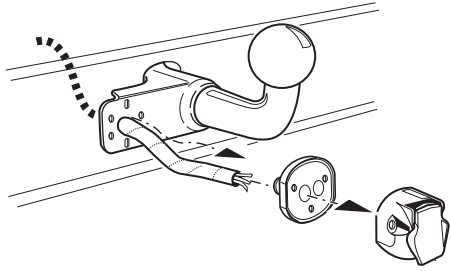

8

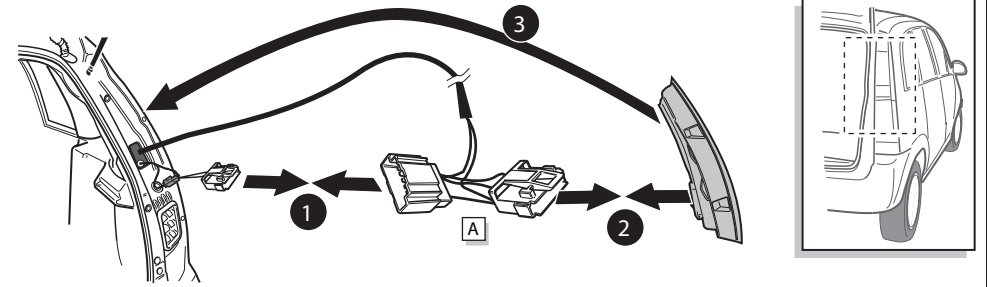

INFO Anschluß Steckdose / Connection de la prise / Socket connection / Contactdoos aansluiting
 Conexión de la caja de enchufe / Allaccio zoccolo / Anslutning kontaktbosa

INFO

DIN/ISO 11446	(DE)	(FR)	(GB)	(NL)	(ES)	(IT)	(SE)	Pmax
1/L	gelb	jaune	yellow	geel	amarillo	giallo	gul	21W
2	blau	bleu	blue	blauw	azul	blu	blå	2x21W
2a	grau	gris	grey	grijs	gris	grigio	grå	
3/31	weiß	blanc	white	wit	blanco	bianco	vit	
4/R	grün	vert	green	groen	verde	verde	grön	21W
5/58-R	braun	marron	brown	bruin	marrón	marrone	brun	52W
6/54	rot	rouge	red	rood	rojo	rosso	röd	3x21W
7/58-L	schwarz	noir	black	zwart	negro	nero	svart	52W
8	schwarz/rot	noir/rouge	black/red	zwart/rood	negro/rojo	nero/rosso	svart/röd	2x21W
9	braun/weiß	marron/blanc	brown/white	bruin/wit	marrón/blanco	marrone/bianco	brun/vit	180W / 15Amp
10	—	—	—	—	—	—	—	
11	—	—	—	—	—	—	—	
12	—	—	—	—	—	—	—	
13	weiß	blanc	white	wit	blanco	bianco	vit	

9

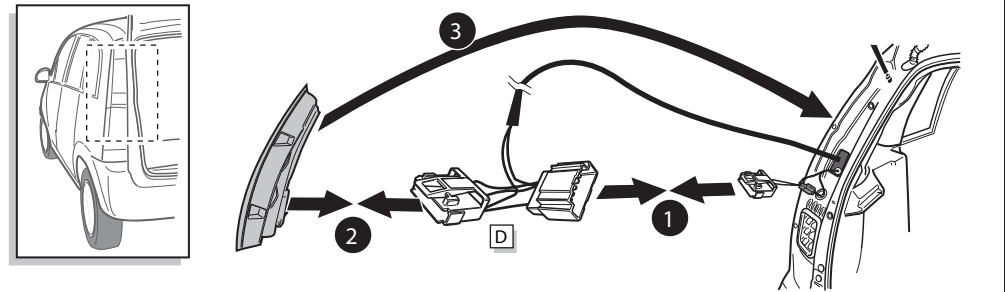

10

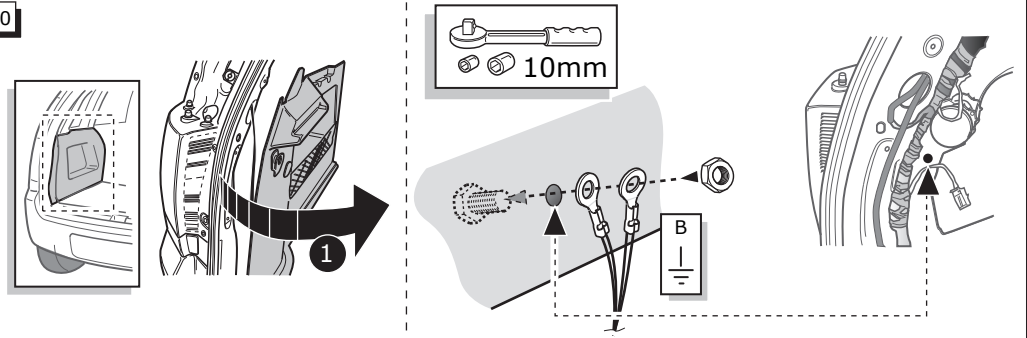

7

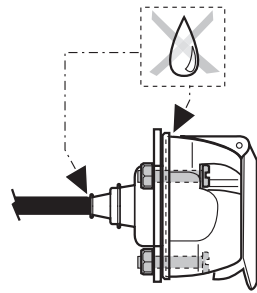
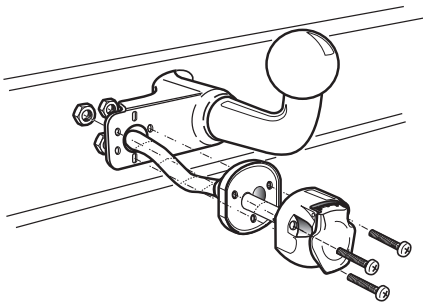

11

