

Einbauanleitung Elektrosatz  
Anhängervorrichtung mit 13-P Steckdose  
lt. DIN/ISO Norm 11446

Instructions de montage du faisceau  
électrique pour crochet d'attelage  
conforme à la norme  
DIN/ISO 11446 prise 13-P

Fitting instructions electric wiringkit  
towbar with 13-P socket up to  
DIN/ISO norm 11446

Montage-handleiding elektrokabelset voor  
trekhaak met 13-P contactdoos  
vlgs. DIN/ISO norm 11446

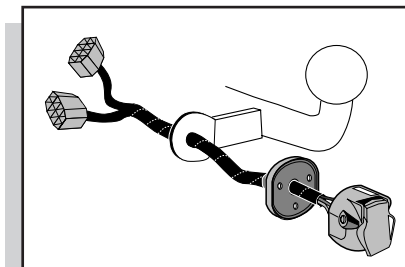

## MAZDA DEMIO 1998

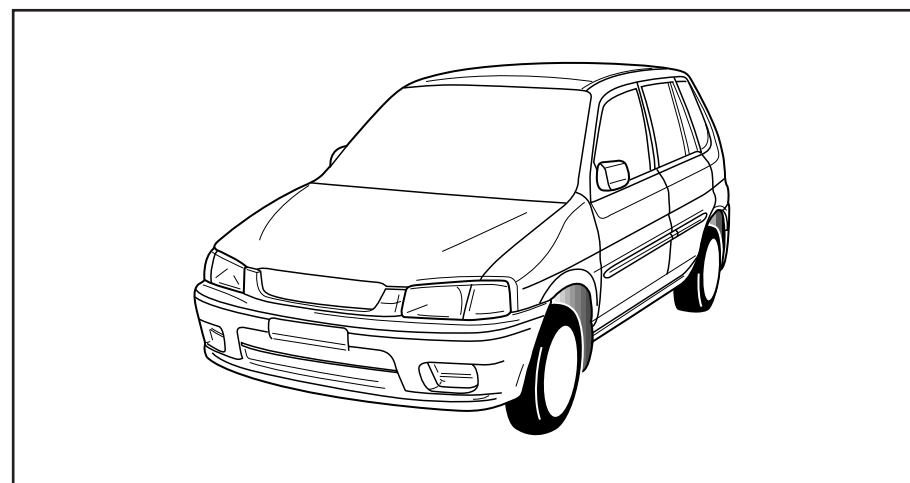

Bestel Nr.: MZ-010-HB



13

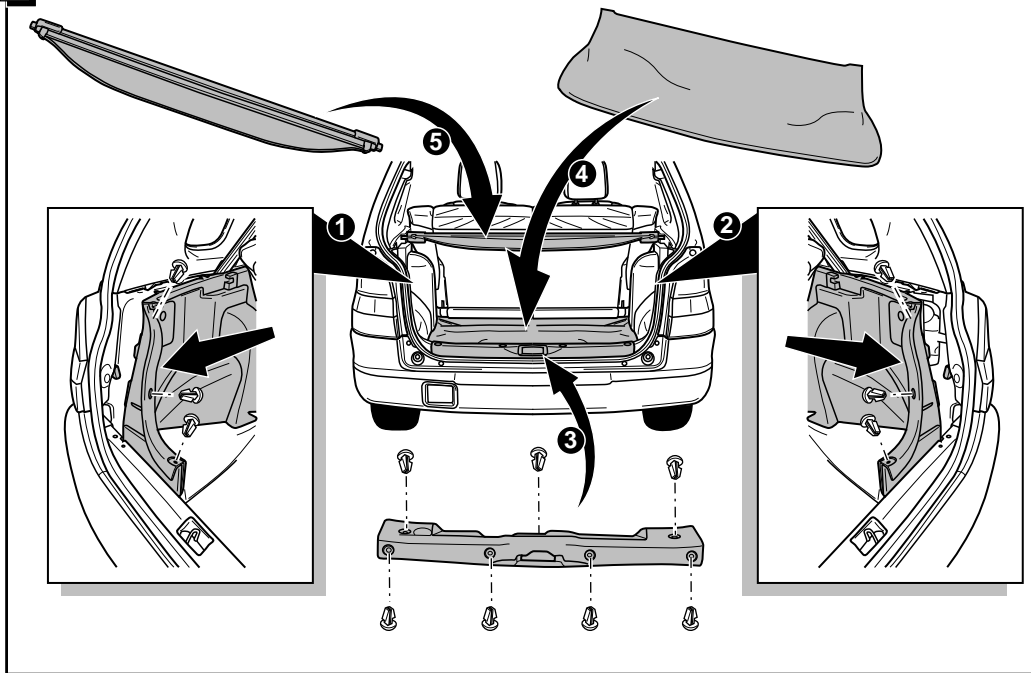

1

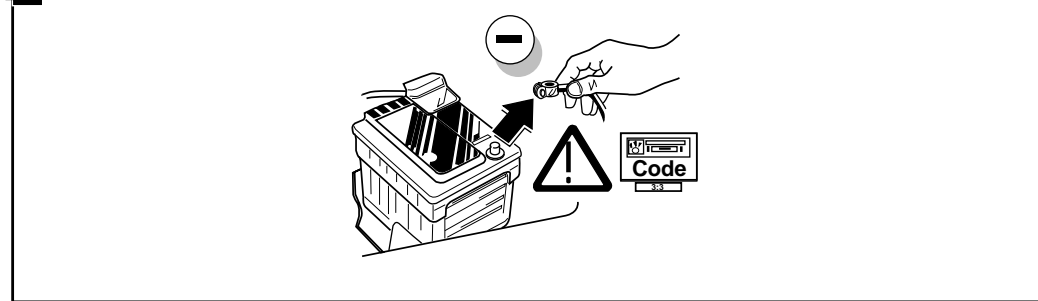

2

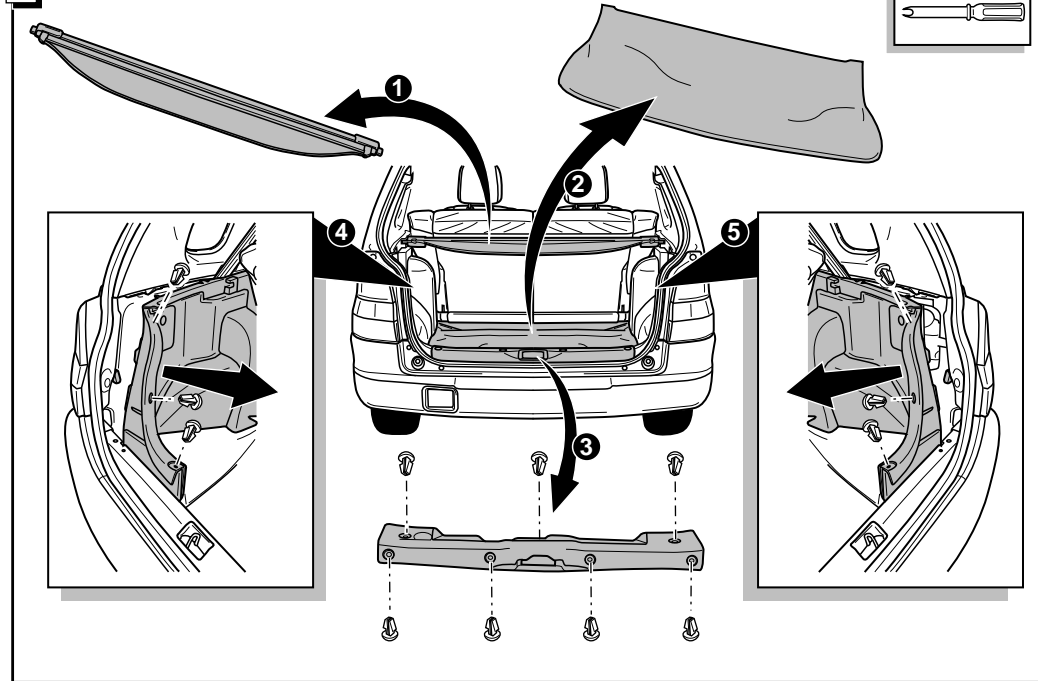

INFO

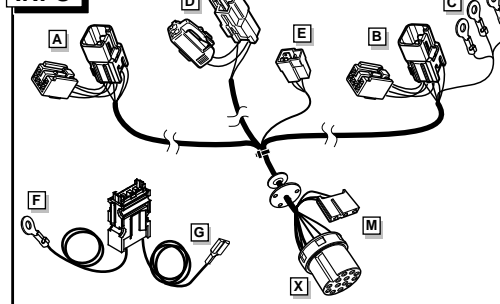

3

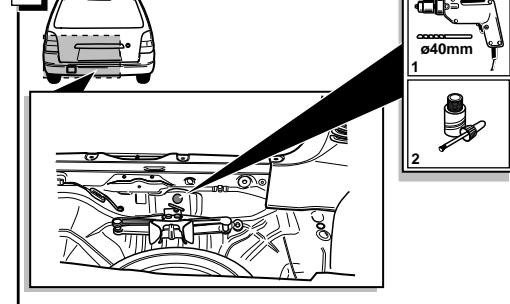

**ROUTING**

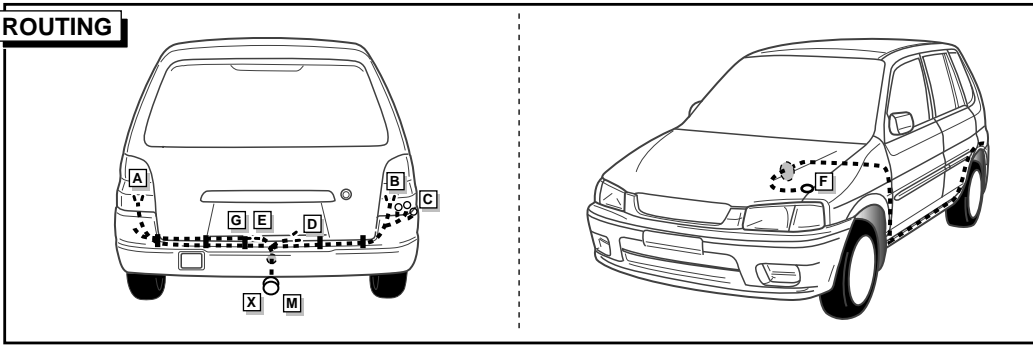

**INFO**

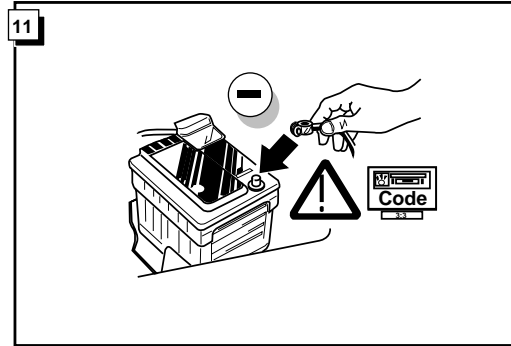
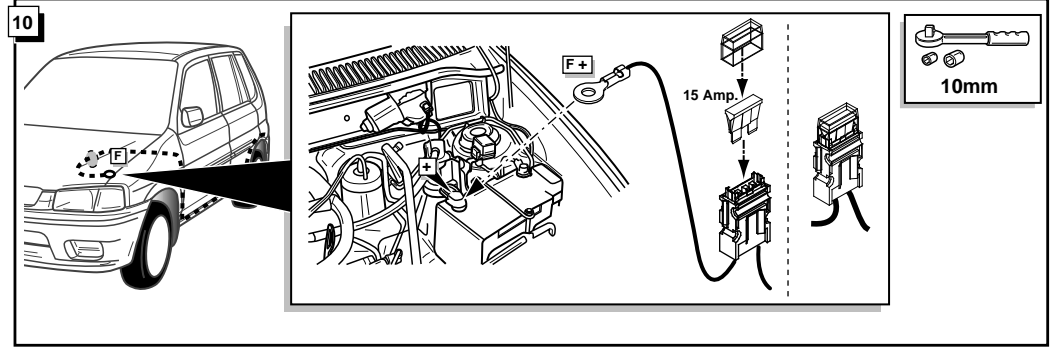
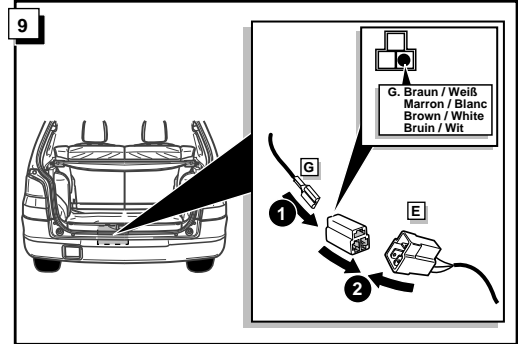
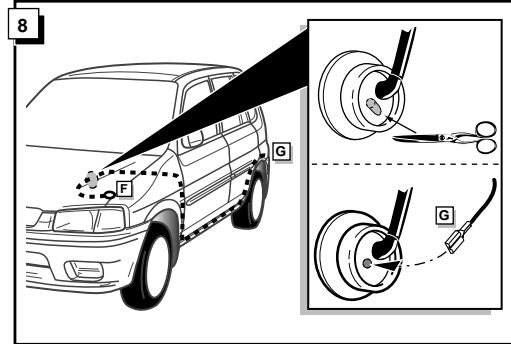
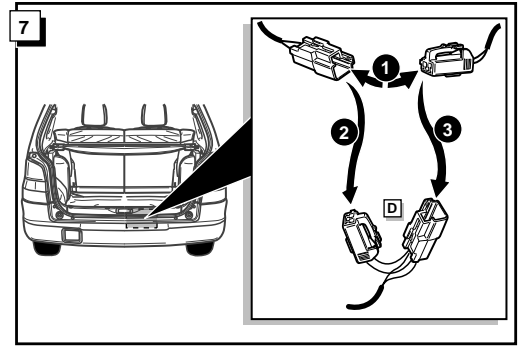
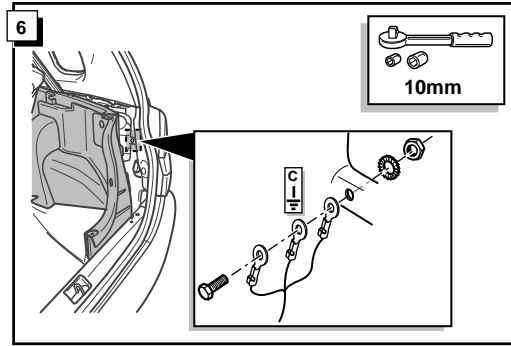
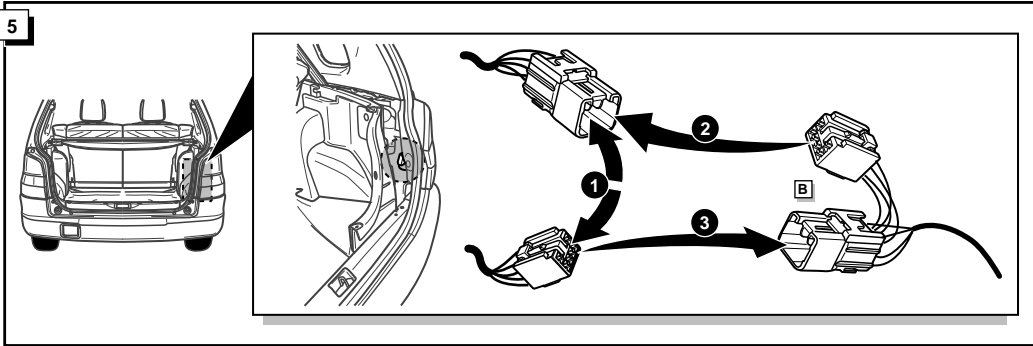
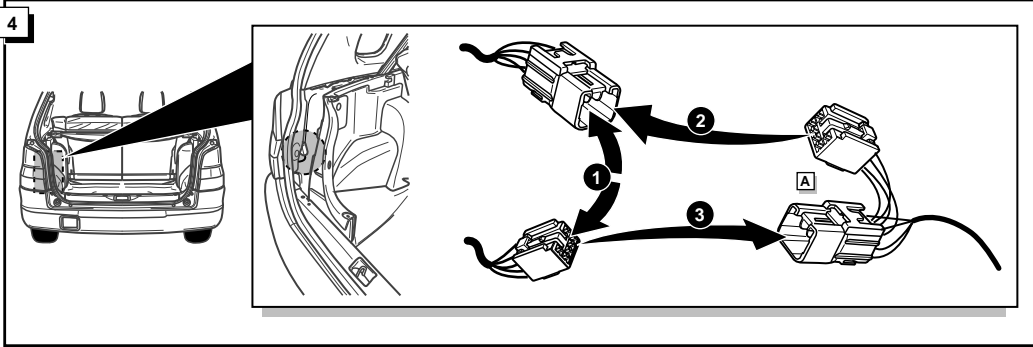
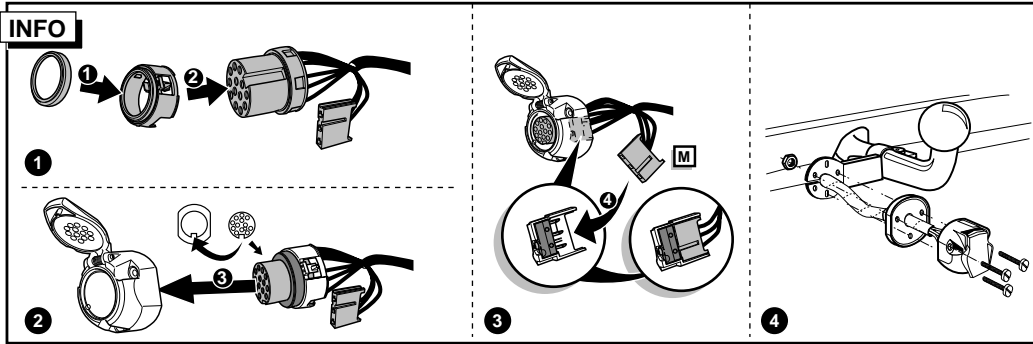

**12**

**FUNKTIONEN KONTROLIEREN !**  
**CONTRÔLER LES FONCTIONS !**  
**CHECK FUNCTIONS !**  
**CONTROLEER FUNCTIES !**