

**Einbauanleitung Elektrosatz  
Anhängervorrichtung mit 13-P Steckdose  
lt. DIN/ISO Norm 11446**

**Instructions de montage du faisceau  
électrique pour crochet d'attelage  
conforme à la norme  
DIN/ISO 11446 prise 13-P**

**Fitting instructions electric wiringkit  
towbar with 13-P socket up to  
DIN/ISO norm 11446**

**Montage-handleiding elektrokabelset voor  
trekhaak met 13-P contactdoos  
vlg. DIN/ISO norm 11446**

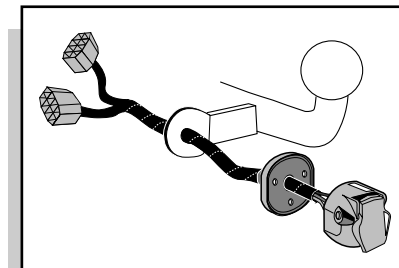

MITSUBISHI PAJERO SPORT 1999-

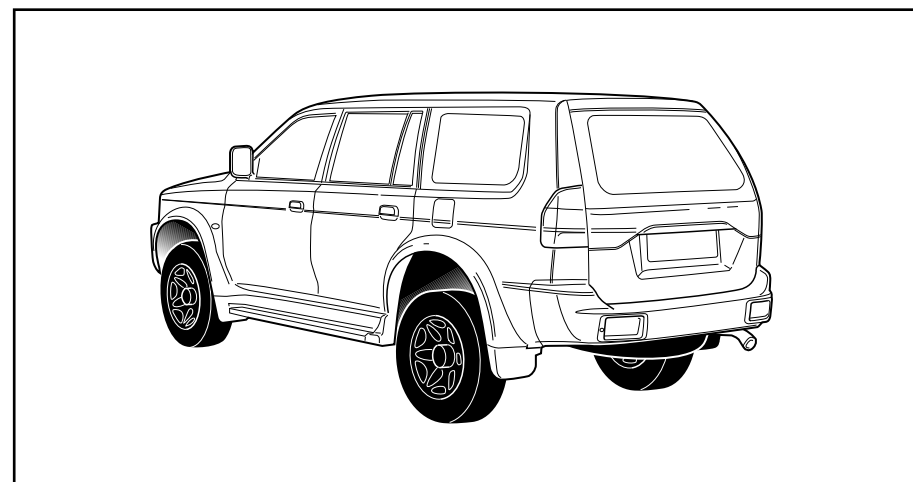

Bestel Nr.: MT-004-HL



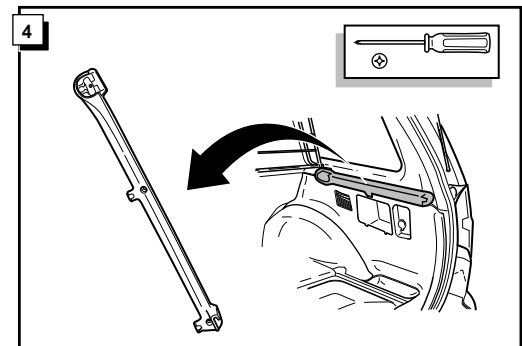
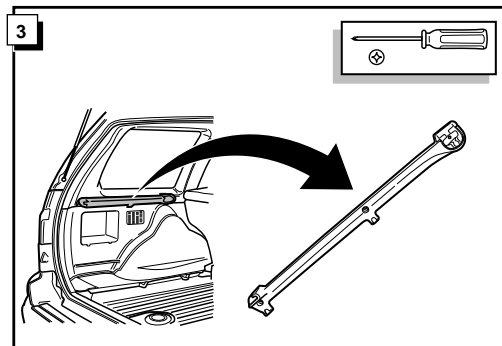
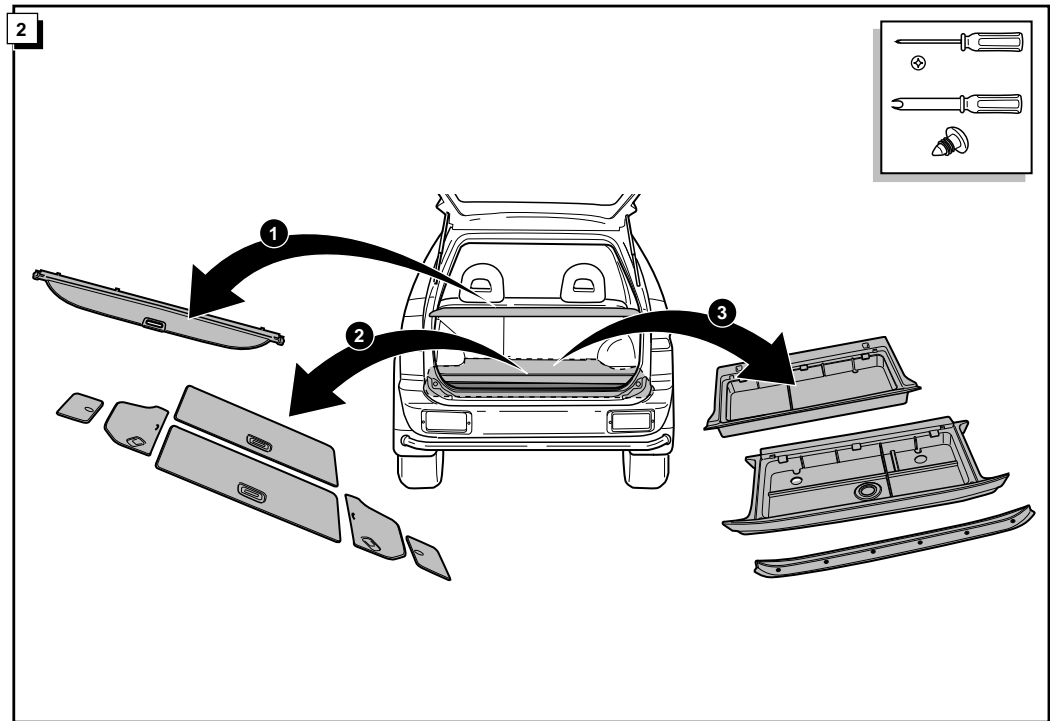
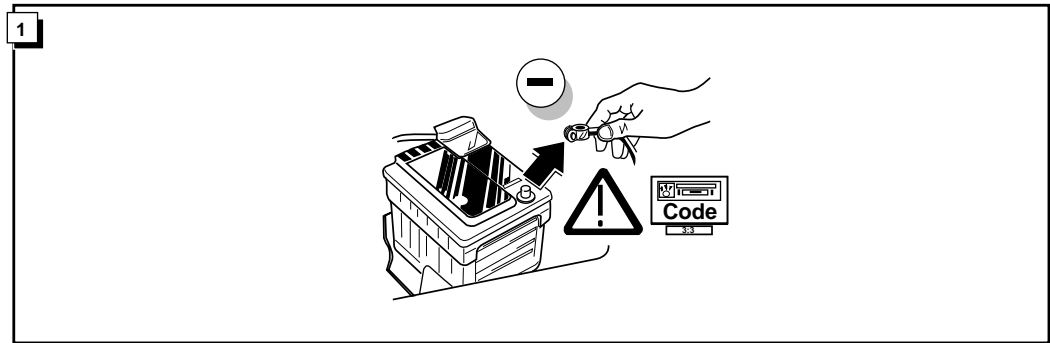

5

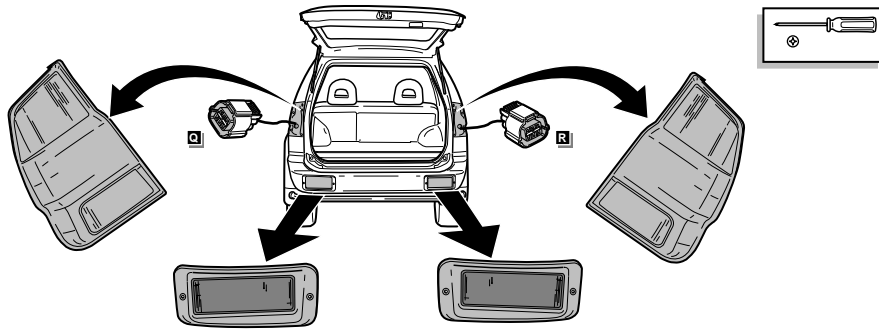

INFO

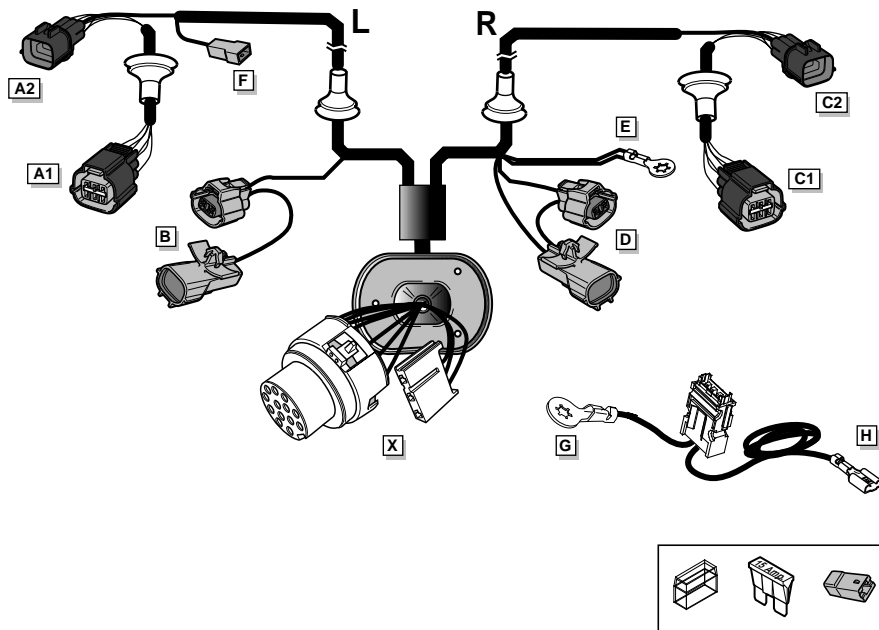

ROUTING

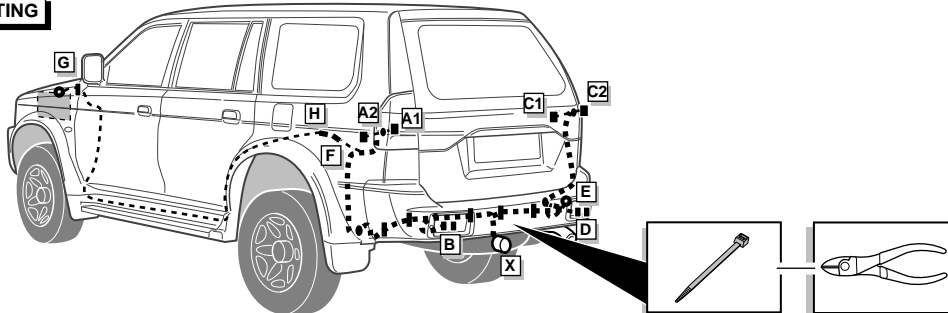

6

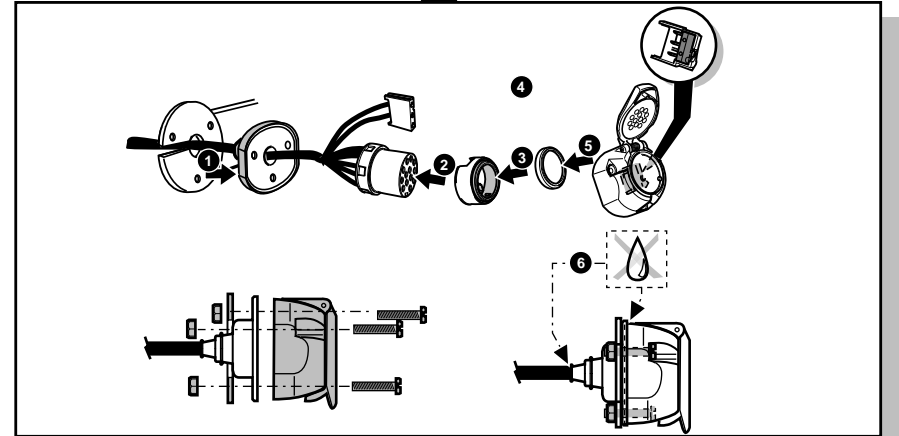
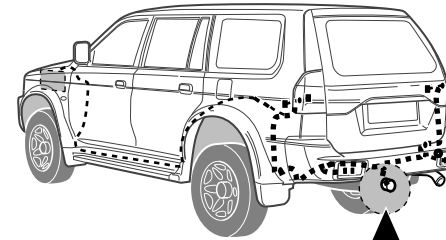

7

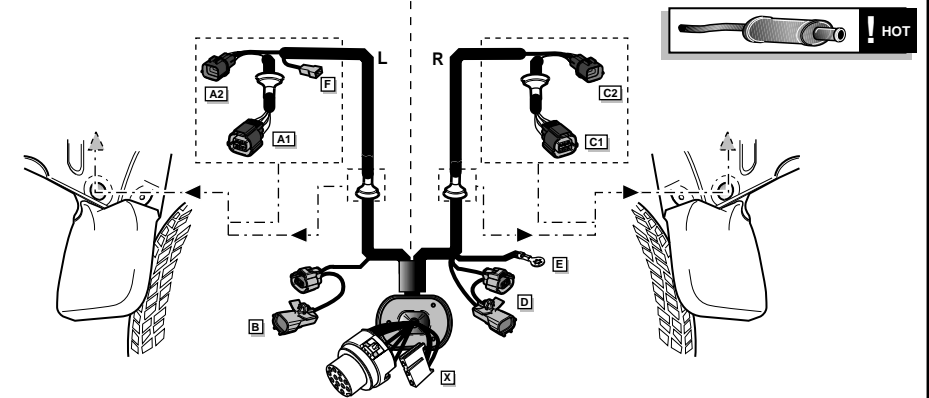
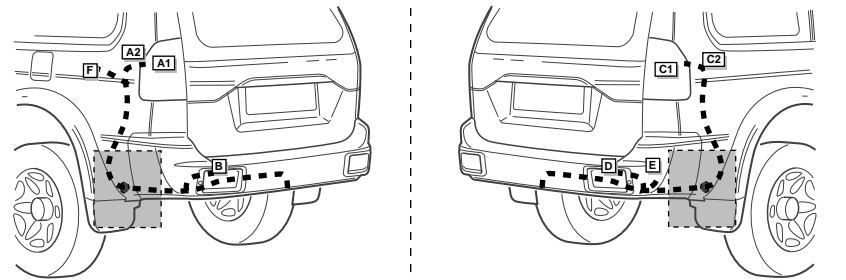

**INFO** Anschluß Steckdose / Connection de la prise / Socket connection / Contactdoos aansluiting

DIN/ISO 11446		(D)	(F)	(GB)	(NL)
	1/L	gelb	jaune	yellow	geel
	2	blau	bleu	blue	blauw
	2a	grau	gris	grey	grijs
	3/31	weiß	blanc	white	wit
	4/R	grün	vert	green	groen
	5/58-R	braun	marron	brown	bruin
	6/54	rot	rouge	red	rood
	7/58-L	schwarz	noir	black	zwart
	8	schwarz/rot	noir/rouge	black/red	zwart/rood
	9	braun/weiß	marron/blanc	brown/white	bruin/wit
	10				
	11				
	12				
	13	weiß	blanc	white	wit

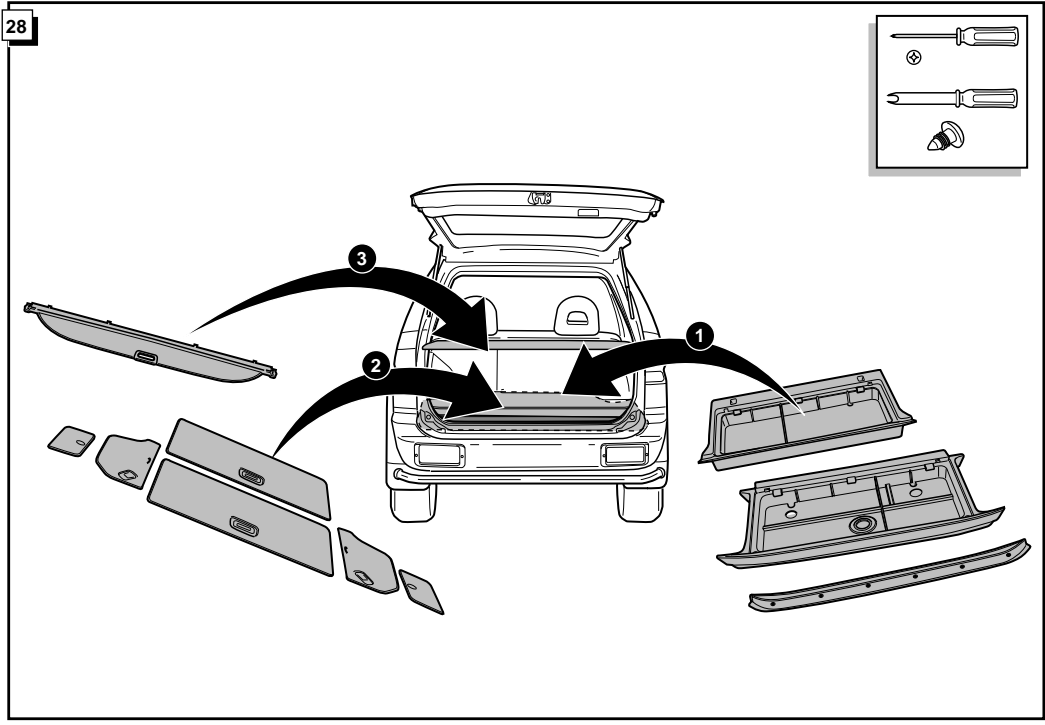
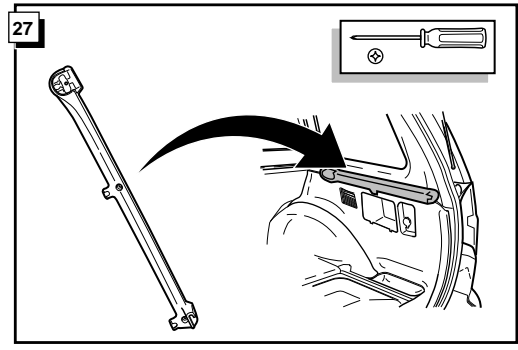
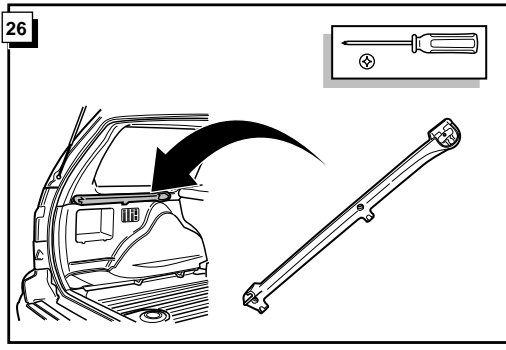
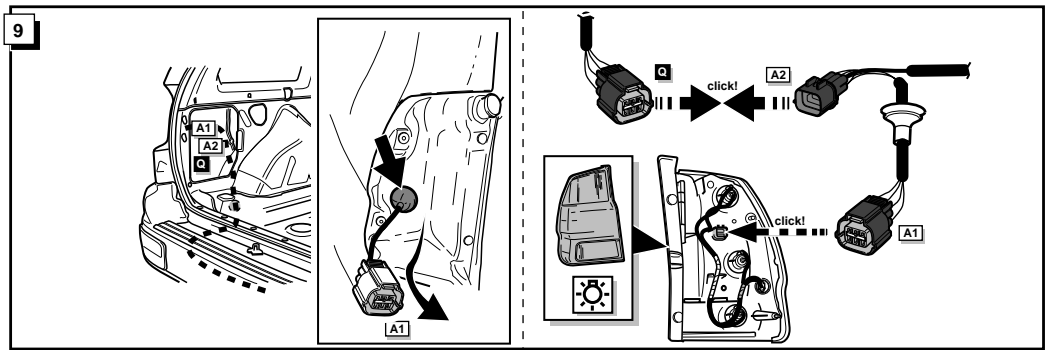
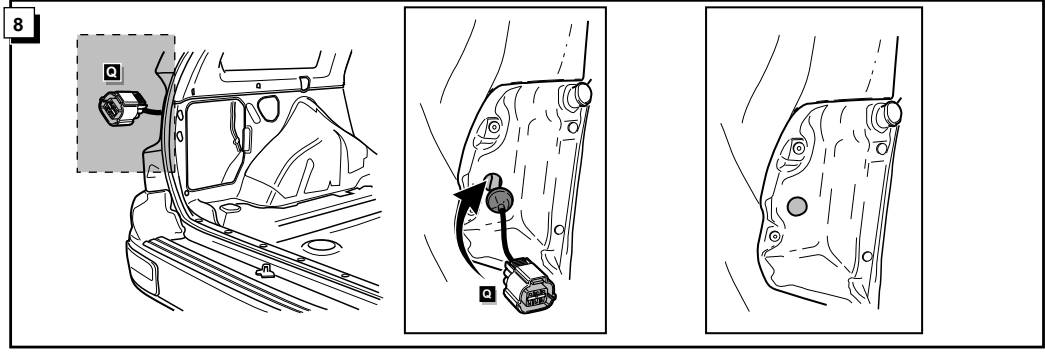

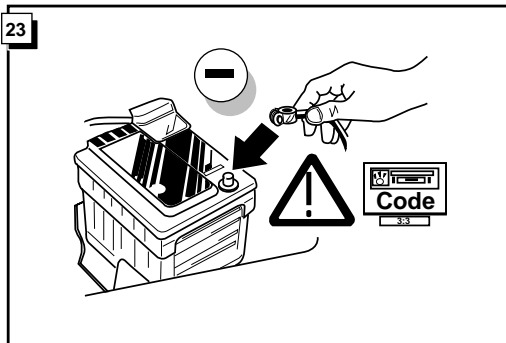
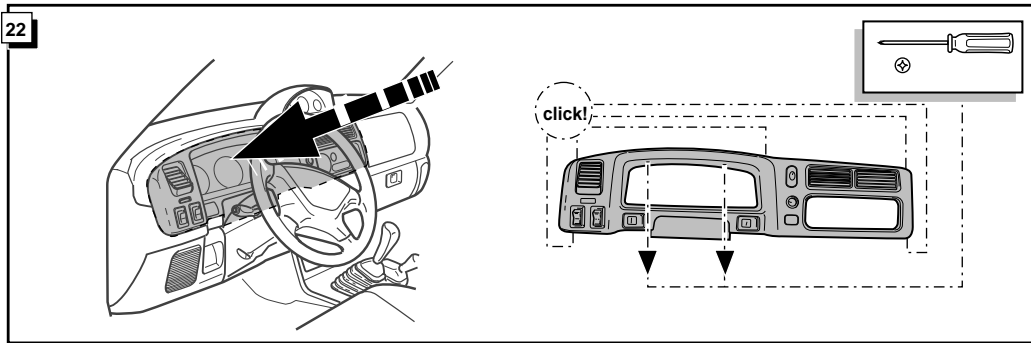

24

**! FUNKTIONEN KONTROLIEREN !**  
**! CONTRÔLER LES FONCTIONS !**  
**! CHECK FUNCTIONS !**  
**! CONTROLEER FUNCTIES !**

**INFO**

Die Kontrollleuchte blinkt, wenn beim angeschlossenen Anhänger die Blinker (3x21W) oder Warnblinkanlage (6x21W) eingeschaltet sind.

Le deuxième témoin de contrôle clignote lorsque les feux de détresses (6x21W) et les clignotants (3x21W) du véhicule sont allumés alors que la caravane/remorque est accouplée au véhicule.

By switching on flashers with the trailer connected (3x21W) or the warning lights (6x21W), the 2nd direction indicator light will flash.

Het controle-lampje knippert wanneer bij aangesloten aanhanger de knipperlichten (3x21W) of waarschuwingslichten (6x21W) ingeschakeld zijn.

