

**Einbauanleitung Elektrosatz
Anhängervorrichtung mit 13-P Steckdose
lt. DIN/ISO Norm 11446**

**Instructions de montage du faisceau
électrique pour crochet d'attelage
conforme à la norme
DIN/ISO 11446 prise 13-P**

**Fitting instructions electric wiringkit
towbar with 13-P socket up to
DIN/ISO norm 11446**

**Montage-handleiding elektrokabelset voor
trekhaak met 13-P contactdoos
vlg. DIN/ISO norm 11446**

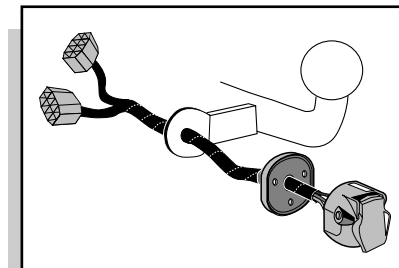

**MERCEDES-BENZ Vaneo COMPACT 2002-
W414**

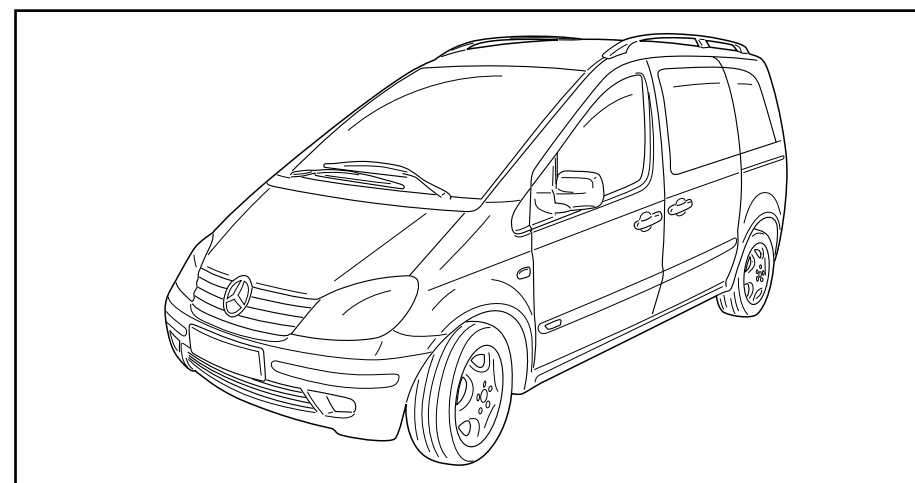

Bestel Nr.: MB-050-DL

* Teilliste

* Liste de pieces

* Part list

* Onderdelenlijst

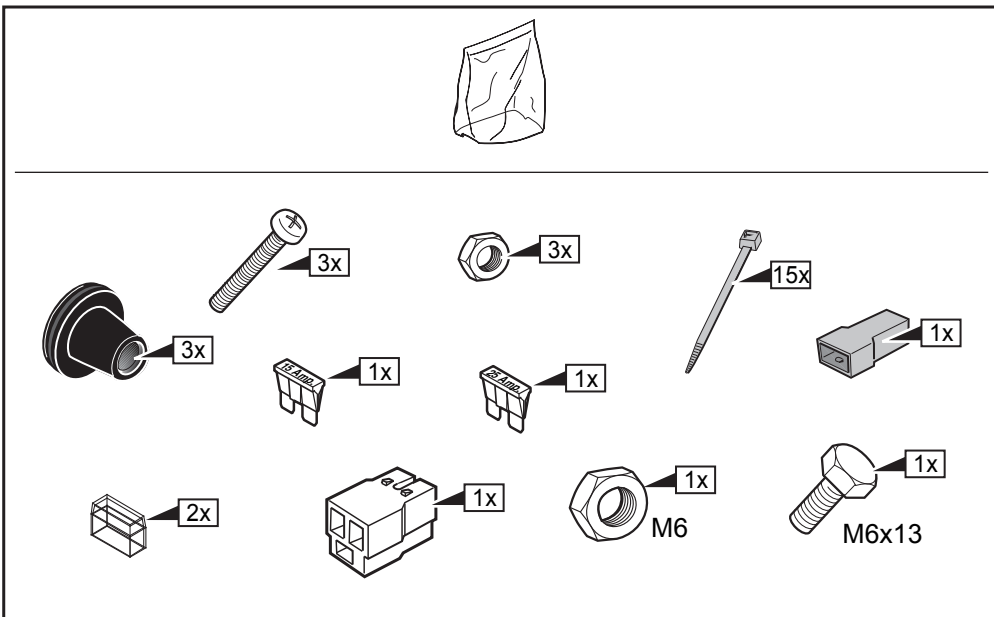
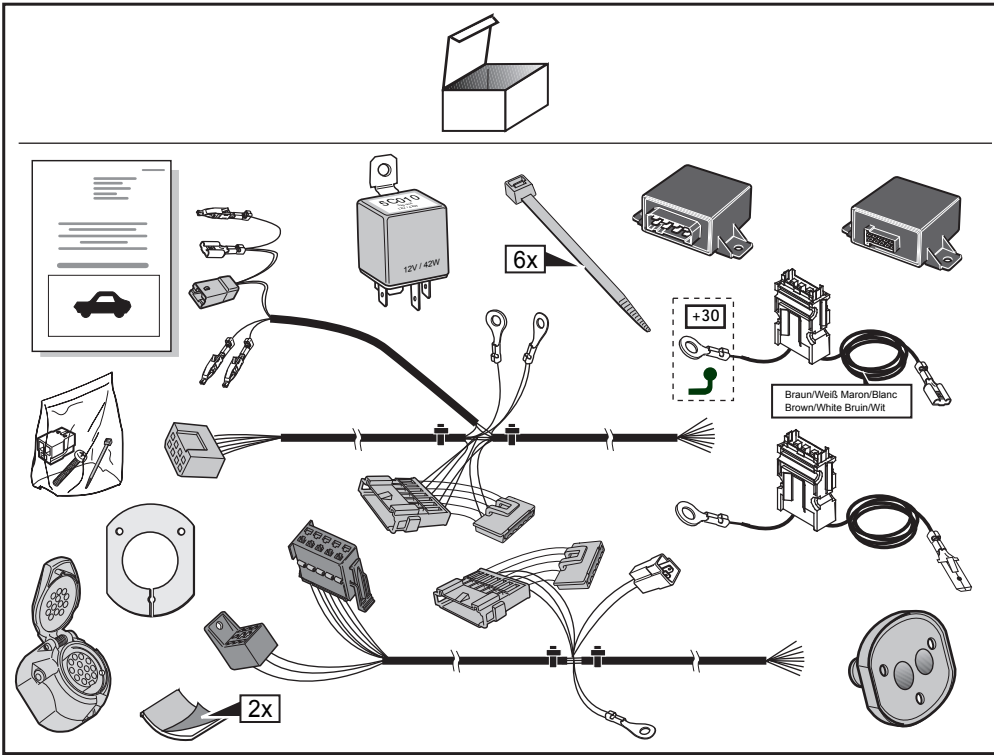

INFO

*Die Wirkung des C2-Steuergeräts kann mittels des Anschlusses des Anhängers (oder Testkasten mit 21W Lampen) und der Anschaltung des Blinkgebers mit einem ausgedrehten Blinklicht geprüft werden. Die andere Blinklichter blinken dann schneller. (Achtung: Ein Testkasten wo ausschließlich LED's als Belastung verwendet werden, kann hierfür nicht verwendet werden).

*Le fonctionnement du module C2 peut être contrôlé en branchant une remorque/caravane (ou boîte test avec des lampes 21W) et en indiquant une direction avec une lampe clignotante dévissée. Les autres lampes clignotantes clignotent alors plus rapidement. (Attention: une boîte test où ne sont utilisés que les témoins de contrôle comme charge, ne peut être utilisé dans ce cas.)

*The functioning of the C2-module can be tested by connecting the trailer/caravan (or a test-box with 21W lamps) and switching on the indicator lights with a removed indicator light. The other indicator lights will flash quicker. (ATTENTION: a test-box on which only LED's are being used, can not be used in this case.)

*De werking van de C2-module kan getest worden door een aanhanger (of testkast met 21W lampen) aan te sluiten en met een losgedraaid knipperlicht richting aan te geven. De andere knipperlichten knipperen nu snel. (LET OP: een testkast waar uitsluitend LED's als belasting gebruikt worden, kan hiervoor niet worden gebruikt.)

26

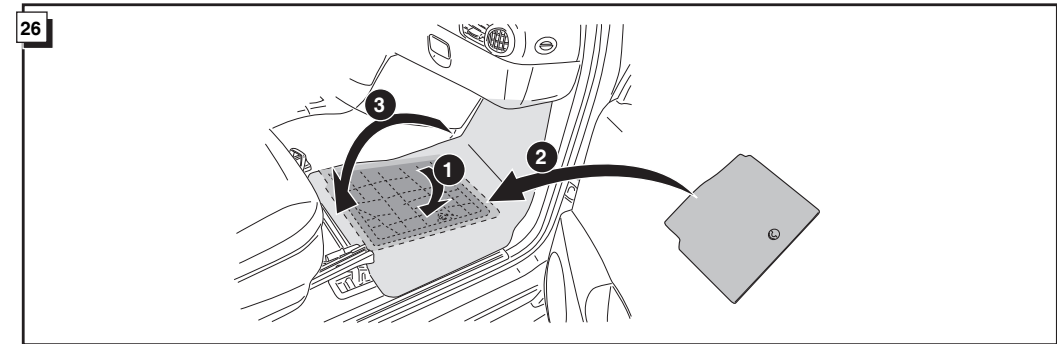

27

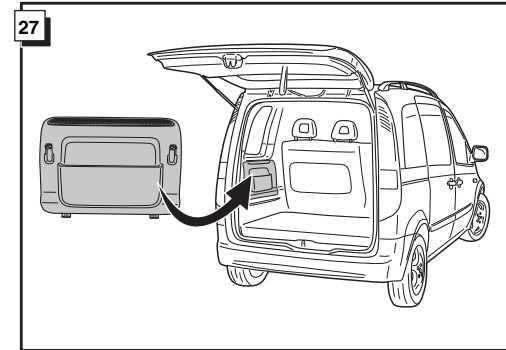

28

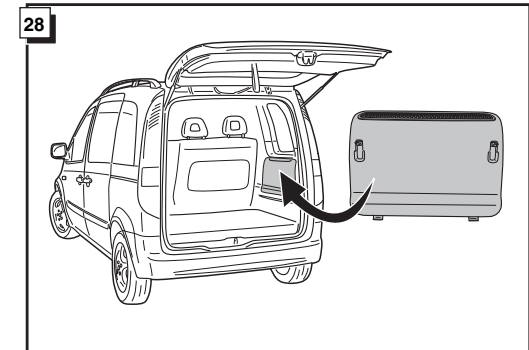

29

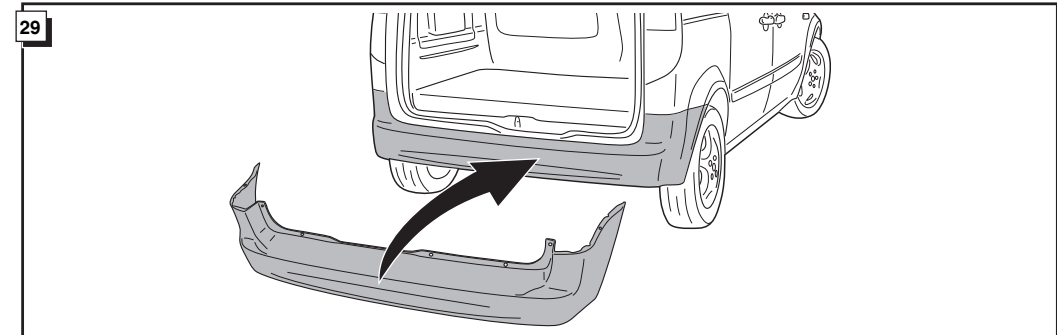

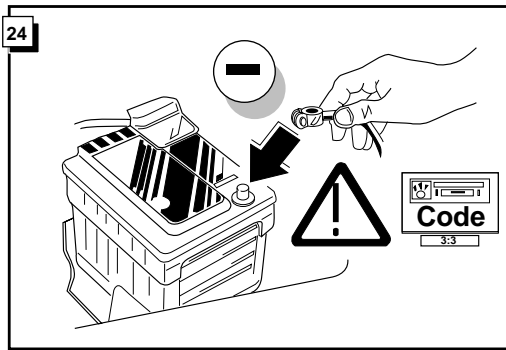
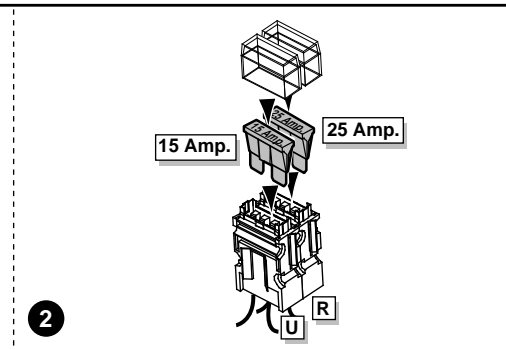
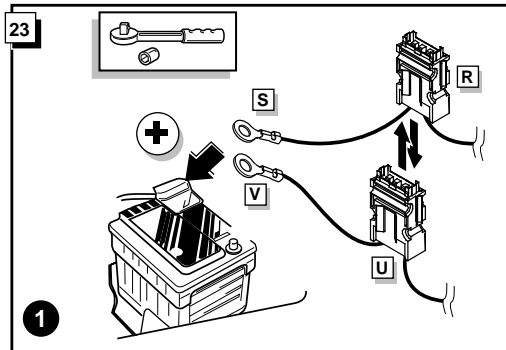
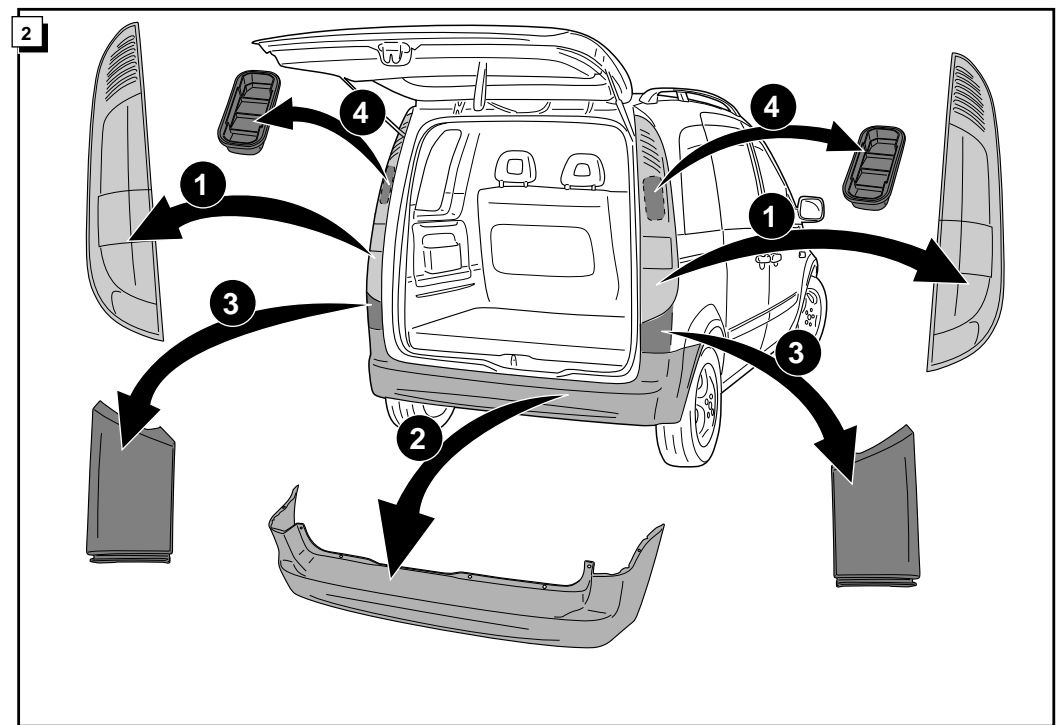
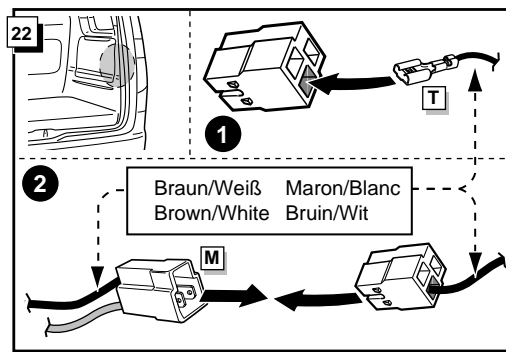
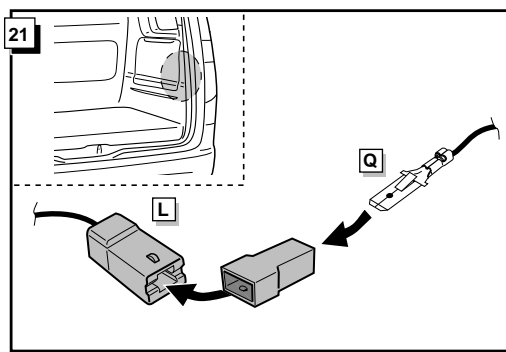
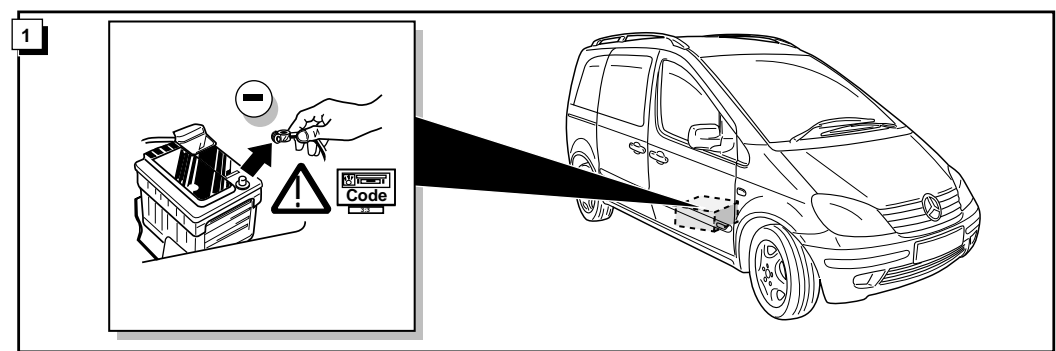
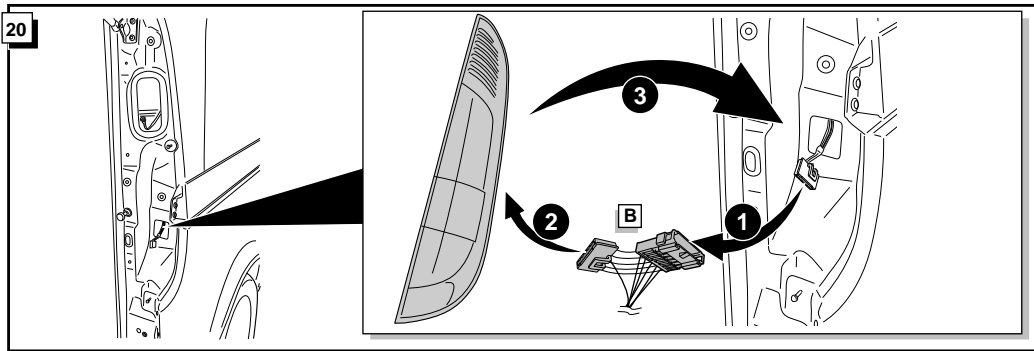

25

! FUNKTIONEN KONTROLLIEREN !
! CONTRÔLER LES FONCTIONS !
! CHECK FUNCTIONS !
! CONTROLEER FUNCTIES !

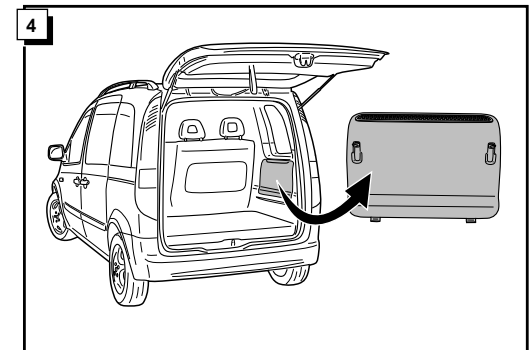
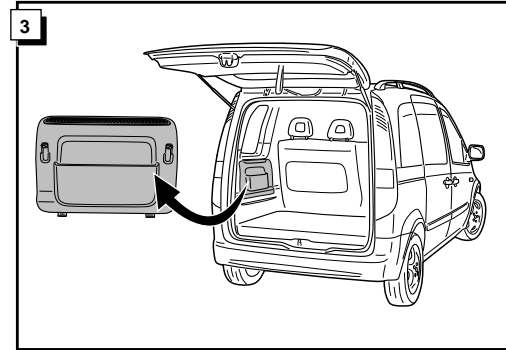

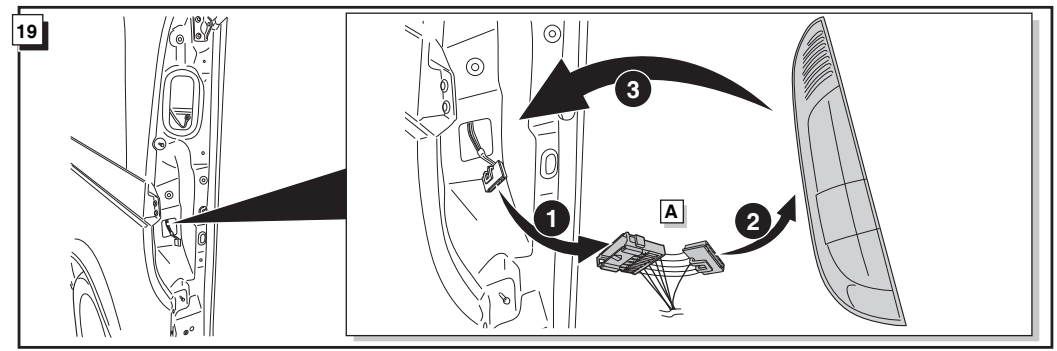
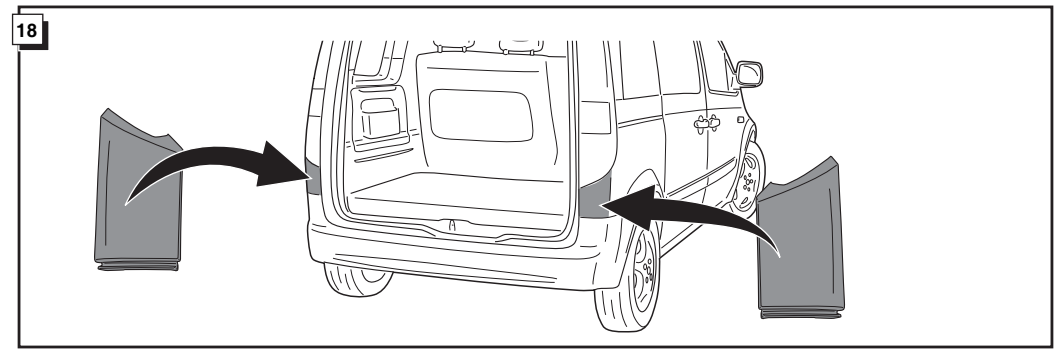
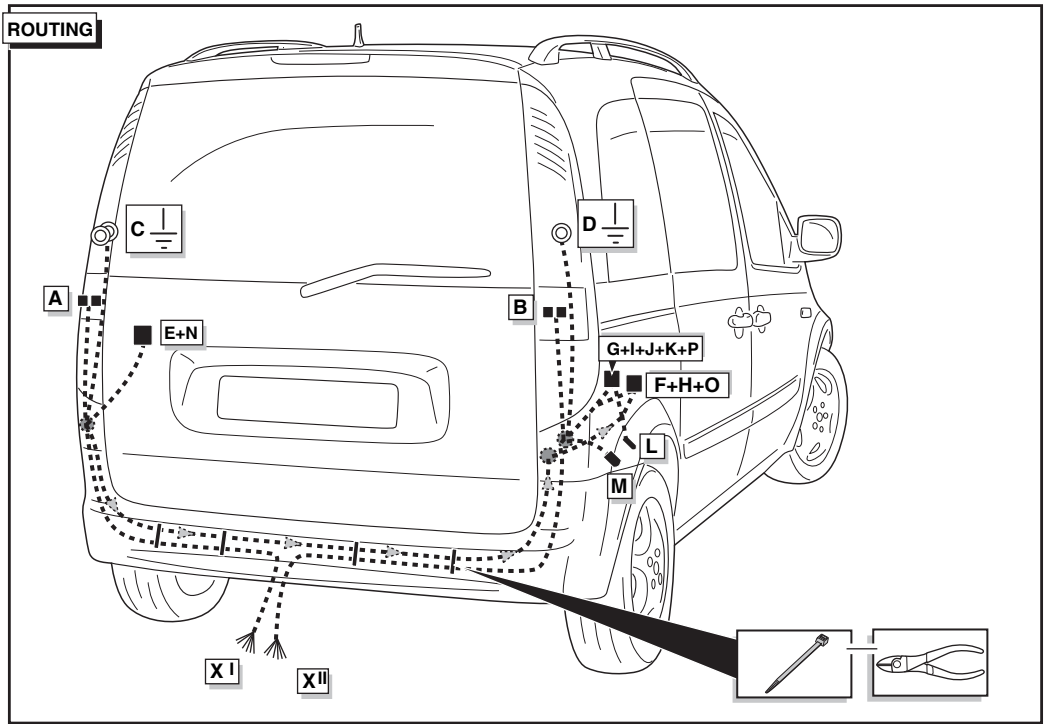
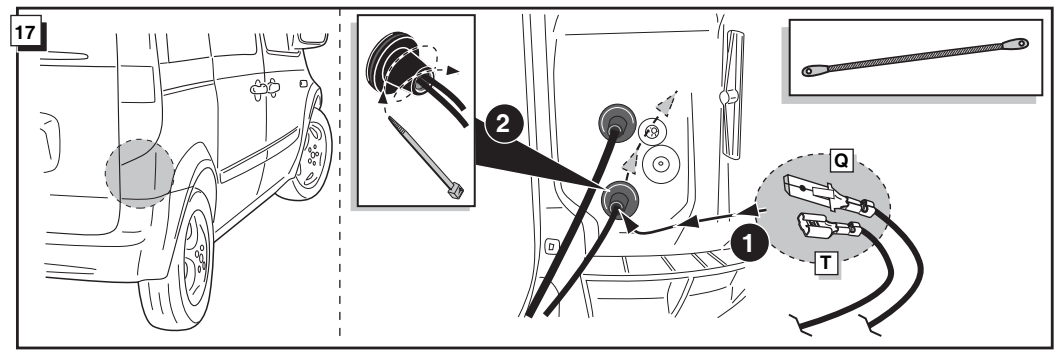
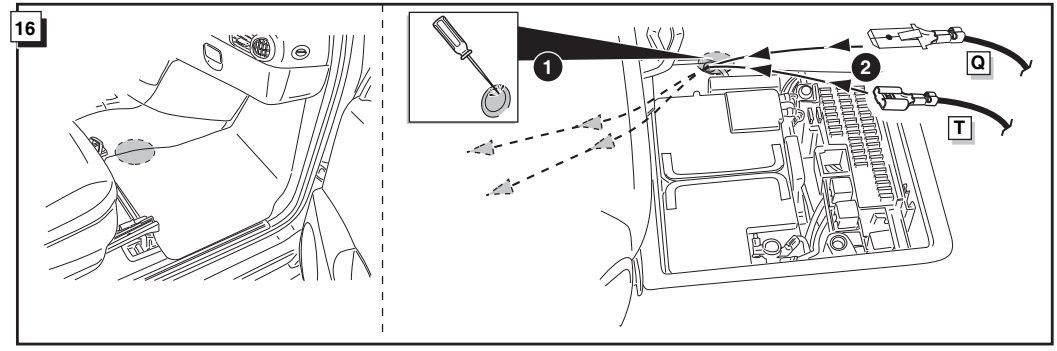
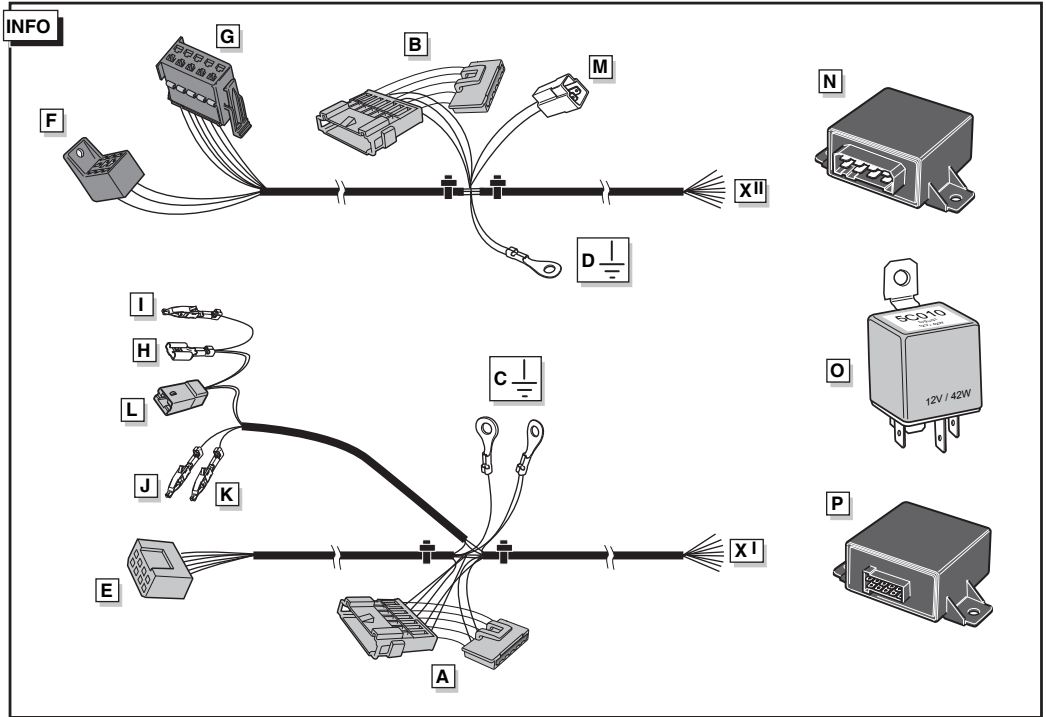

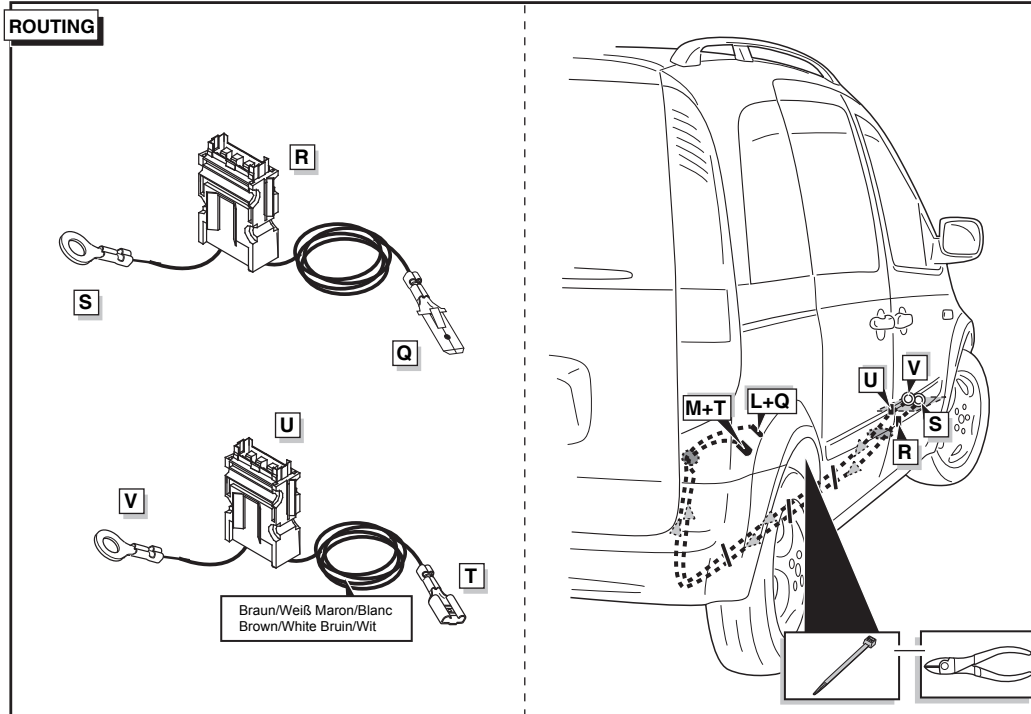
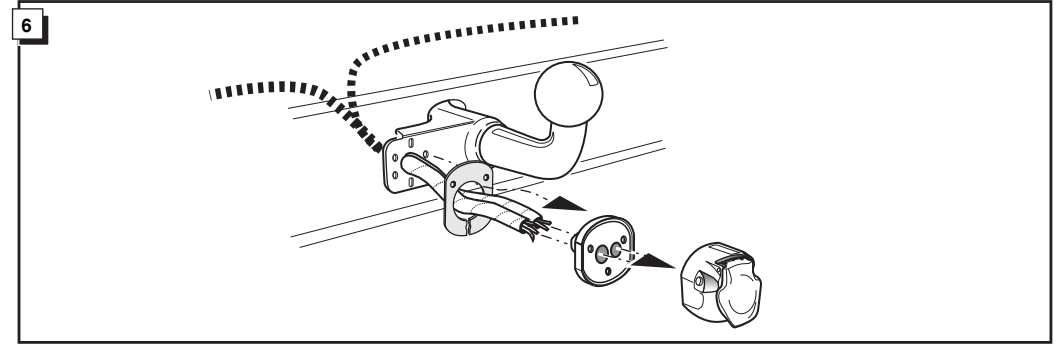
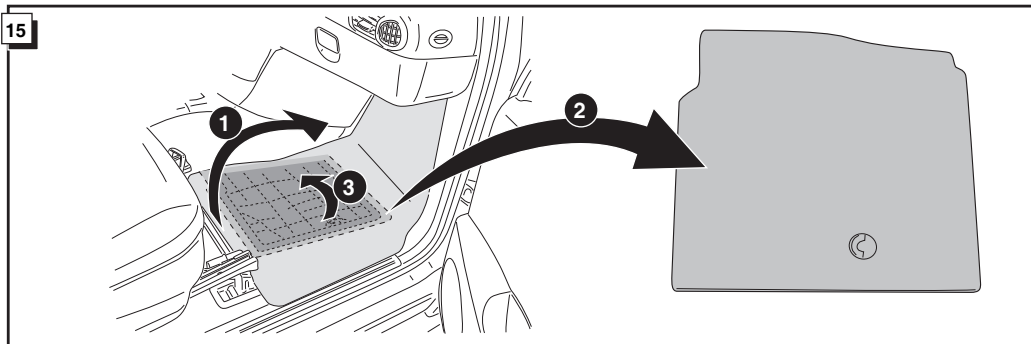
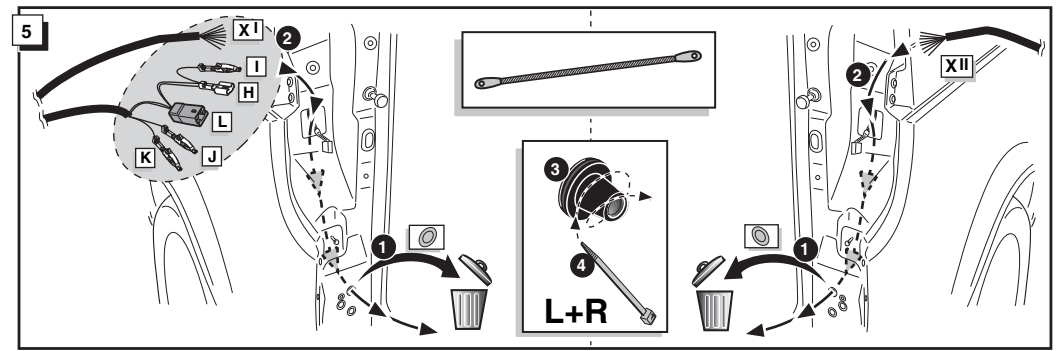
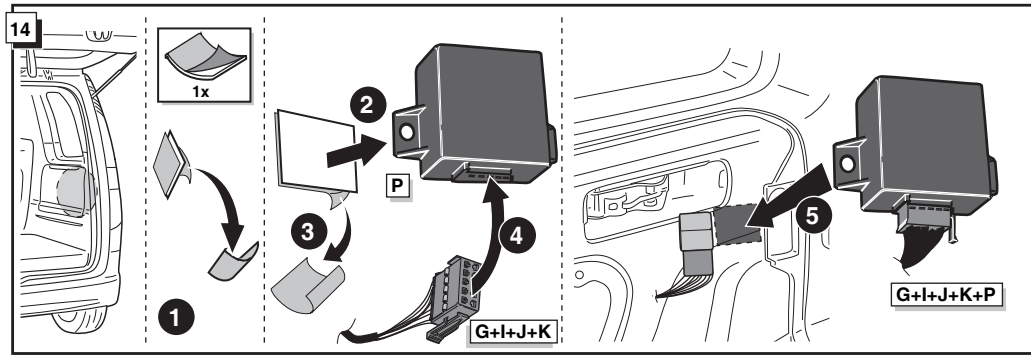

INFO Anschluß Steckdose / Connection de la prise / Socket connection / Contactdoos aansluiting

DIN/ISO 11446		(D)	(F)	(GB)	(NL)	Pmax
←	1/L	gelb	jaune	yellow	geel	21W
↻	2	blau	bleu	blue	blauw	2x21W
↔	2a	grau	gris	grey	grijs	
⊖	1-8	weiß	blanc	white	wit	
↻	4/R	grün	vert	green	groen	21W
☀	5/58-R	braun	marron	brown	bruin	52W
STOP	6/54	rot	rouge	red	rood	3x21W
☀	7/58-L	schwarz	noir	black	zwart	52W
↻	8	schwarz/rot	noir/rouge	black/red	zwart/rood	2x21W
30+	9	braun/weiß	marron/blanc	brown/white	bruin/wit	180W / 15 Amp
15+	10	rot	rouge	red	rood	180W / 15 Amp
⊖	10	weiß	blanc	white	wit	
↻	12	rot/blau	rouge/bleu	red/blue	rood/blauw	
⊖	9	weiß	blanc	white	wit	

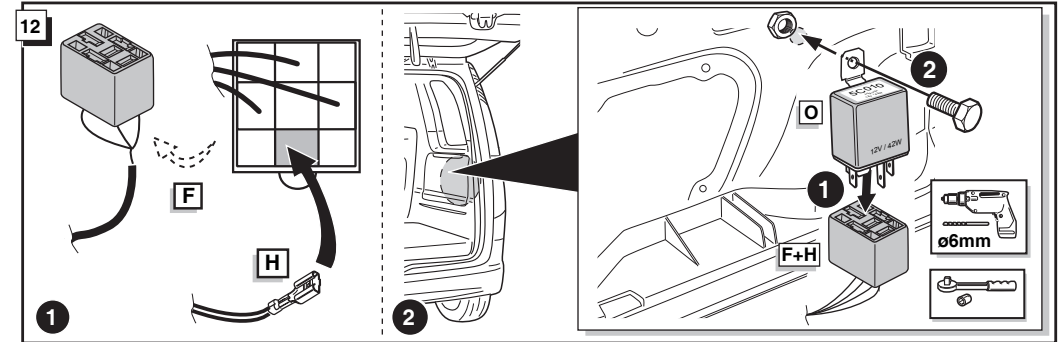
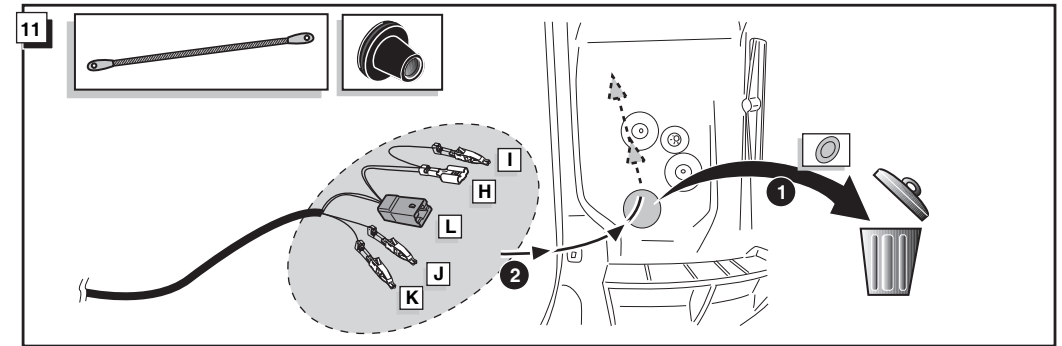
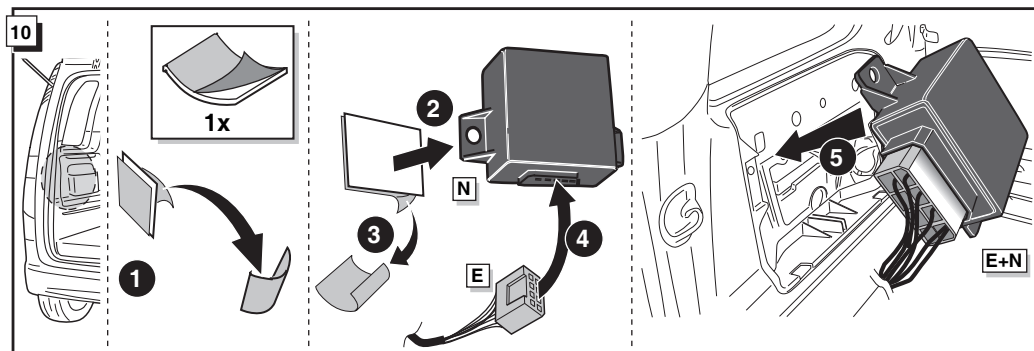
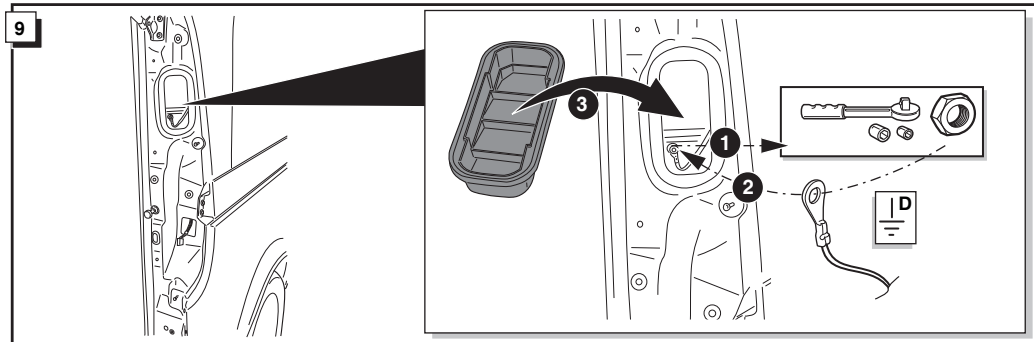
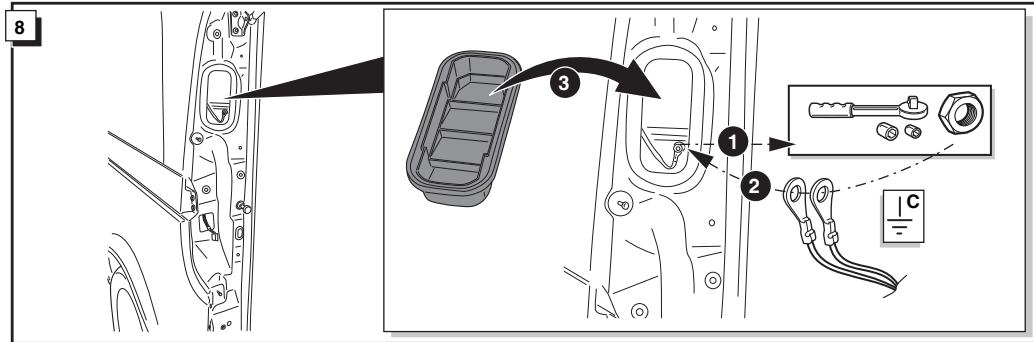
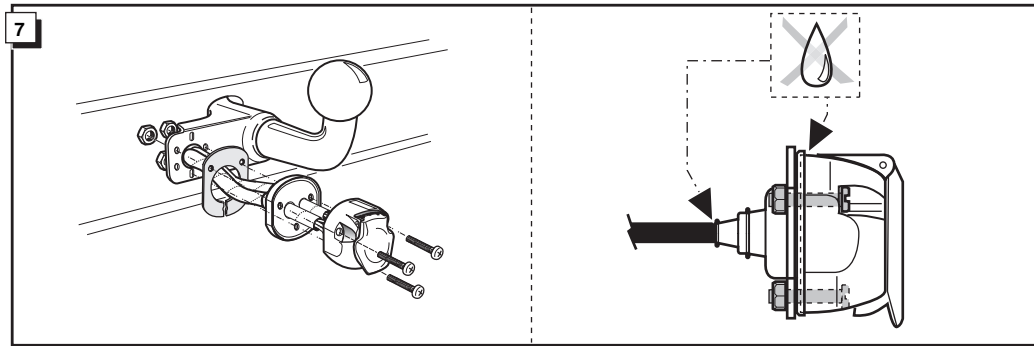

Positie	D	F	GB	NL
1	grün	vert	green	groen
2	weiß/grün	blanc/vert	white/green	wit/groen
3	rot/blau	rouge/bleu	red/blue	rood/blauw
4	schwarz/grün	noir/vert	black/green	zwart/groen
5	weiß	blanc	white	wit
6	schwarz	noir	black	zwart
7				
8	gelb/weiß	jaune/blanc	yellow/white	geel/wit
9	schwarz/gelb	noir/jaune	black/yellow	zwart/geel
10	gelb	jaune	yellow	geel

BLACK / SCHWARZ / ZWART / NOIR
 YELLOW / WHITE / GELB / WEIß / GEEL / WIT / BLANC / JAUNE
 BLACK / YELLOW / SCHWARZ / GELB / ZWART / GEEL / NOIR / JAUNE