

- D** Zurück montieren Teile.
- F** Montez les part enlevés.
- GB** Reinstall linings.
- NL** Terug plaatsen onderdelen.
- I** Rimontare le rimosse.

FIAT STILO 3Dr

Nr.: FI-008-DB



* Teilliste * Liste de pieces * Part list * Onderdelenlijst * Elenco dei componenti

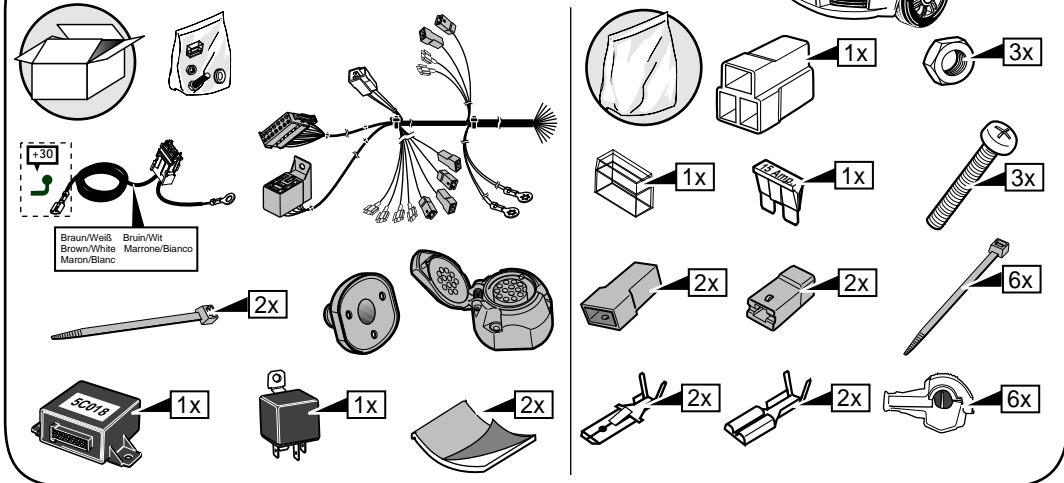

PARK DISTANCE CONTROL (PDC)

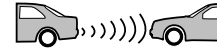

PARK DISTANCE CONTROL (PDC)



Optional set
ECS Nr.: FI-010-ZT

- D** Einbauanleitung Elektrosatz
Anhängervorrichtung mit 13-P
Steckdose lt. DIN/ISO Norm 11446
- F** Instructions de montage du faisceau
électrique pour crochet d'attelage
conforme à la norme
DIN/ISO 11446 prise 13-P
- GB** Fitting instructions electric wiringkit towbar with
13-P socket up to DIN/ISO norm 11446
- NL** Montage-handleiding elektrokabelset voor trekhaak
met 13-P contactdoos vlg. DIN/ISO norm 11446
- I** Istruzioni di montaggio cablaggio elettrico per gancio
traieno con presa 13-P conforme a norma DIN/ISO 11446

D - Wir weisen ausdrücklich darauf hin, das eine unsachgemäße und nicht in einer Fachwerkstätte durchgeführte Montage einen Verzicht auf die Geltendmachung jeglicher Art insbesondere auch aus dem Titel des Produkthaftpflichtrechtes bewirkt.

- Technische Änderungen vorbehalten.
- Belastung nur tabellgemäß auf dem anhängen verwenden, siehe Seite 4.

F - Il est expressément prévu qu' on ne saurait se prévaloir d'un quelconque préjudice contractuel ou rédhibitoire si le montage avait été fait en dépit des dites instructions ou dans un garage ne disposant pas des équipements adéquats.

- Sous réserve de modifications techniques.
- Ne excédez pas la charge maximale, indiquée dans le tableau sur page 4.

GB - We would expressly point out that any improper assembly which is not carried out in a specialist workshop will result in the renunciation of the enforcement of compensation claims of any kind, in particular those arising by virtue of the product liability law.

- Subject to alteration without notice.
- Only use maximum charge according to connectiontable on towed vehicle, see page 4.

NL - Wij wijzen er met nadruk op, dat ondeskundige en niet door een vakkundige werkplaats uitgevoerde montage tot gevolg heeft dat daardoor ieder recht op schadevergoeding, ook op wettelijke aansprakelijkheid inzake producten, vervalt.

- Technische wijzigingen voorbehouden.
- Gebruik alleen belasting volgens aansluittabel op het getrokken voertuig, zie pagina 4.

I - Precisiamo espressamente che il montaggio non effettuato in un'officina di un esperto non darà diritto ad alcun risarcimento di danni anche presentando in virtù della legge di responsabilità del prodotto.

- Soggetto ad alterazioni/modifiche senza avviso.
- Usate soltanto la carica indicata sulla tabella di collegamento del veicolo rimorchiato, vedi pagina 4.



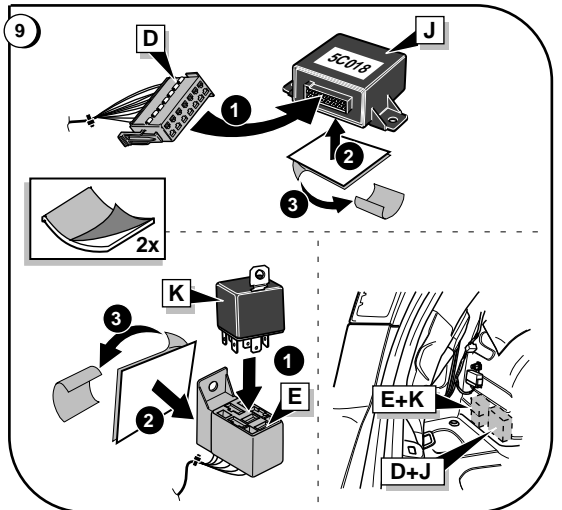
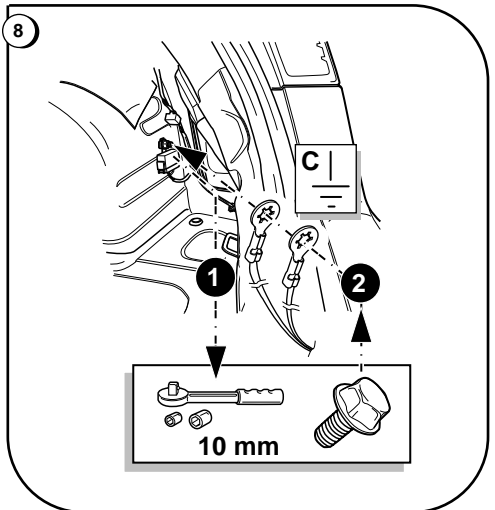
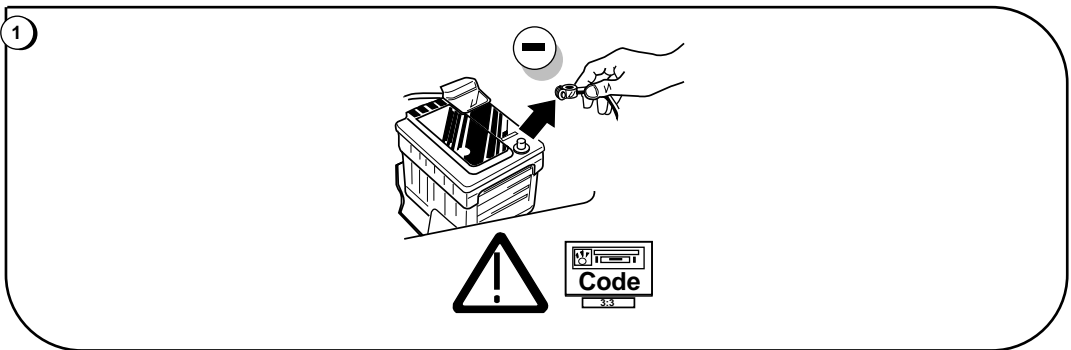

2

D Abmontieren Teile **F** Démontez les parts **GB** Remove linings

NL Verwijder onderdelen **I** Rimuovere il rivestimento

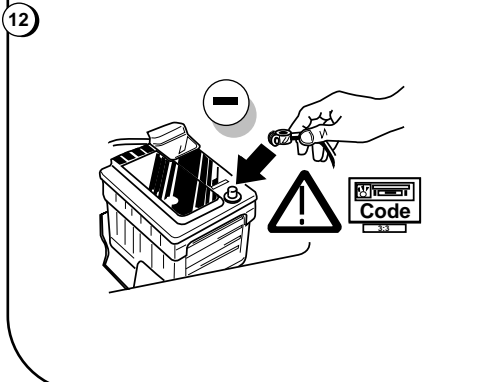
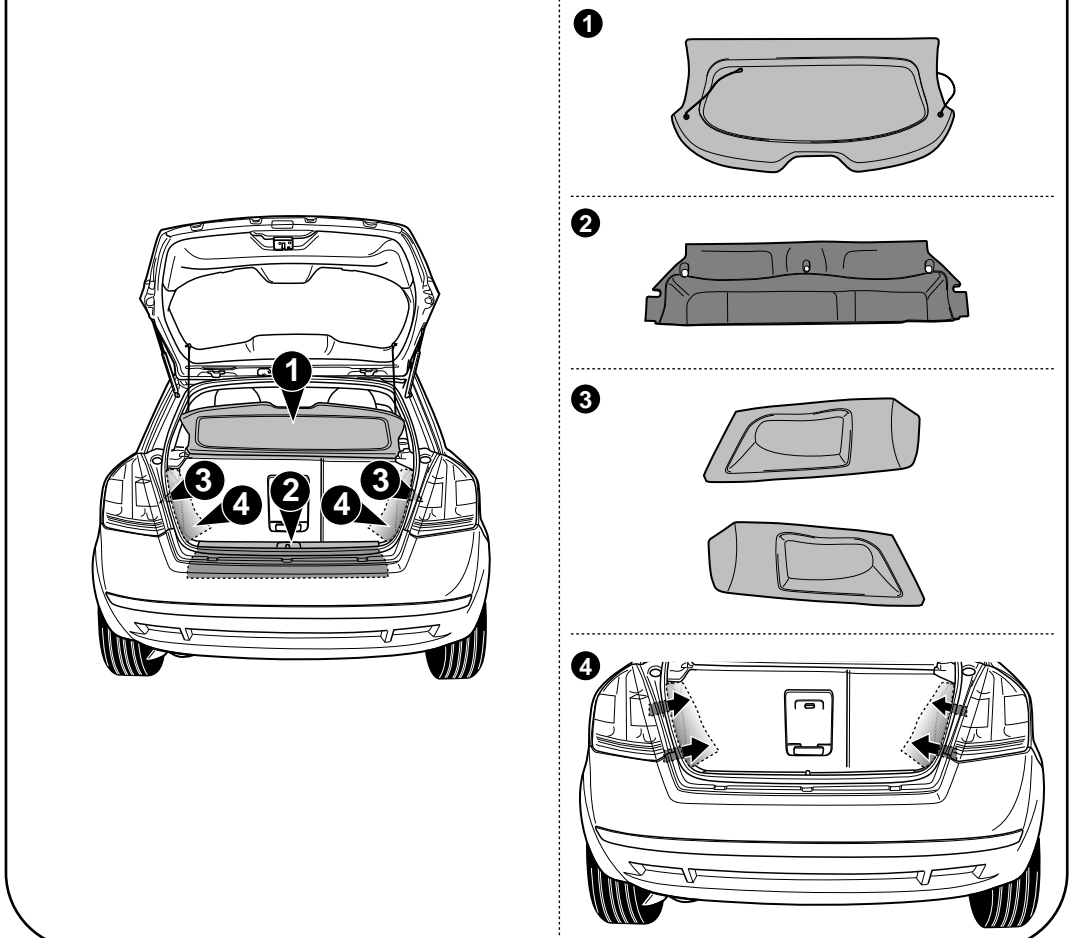
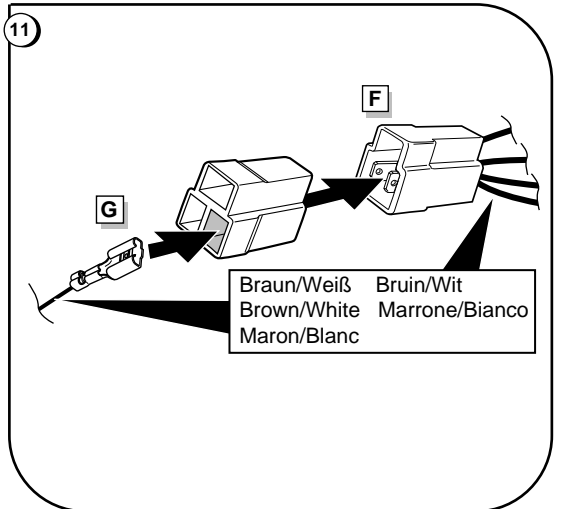
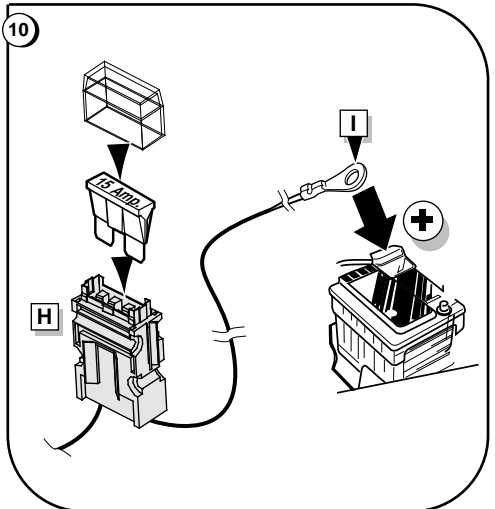

13

D FUNKTIONEN KONTROLLIEREN !

F CONTRÔLER LES FONCTIONS !

GB CHECK FUNCTIONS !

NL CONTROLEER FUNCTIES !

I CONTROLLARE LE FUNZIONI !

7

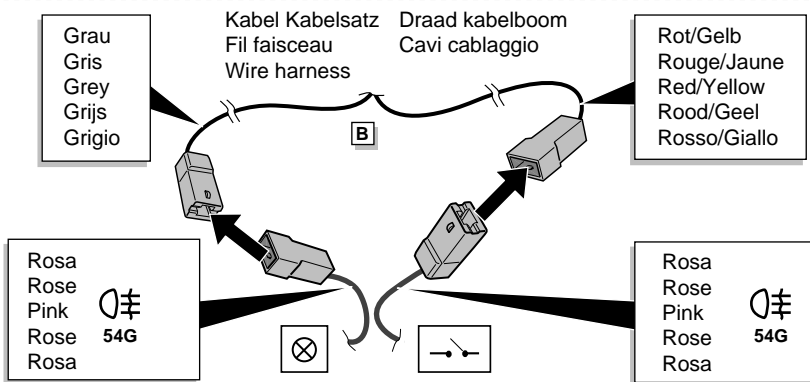
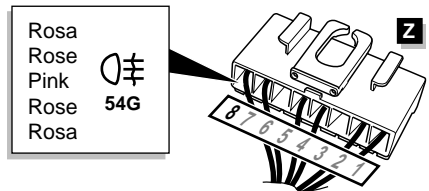
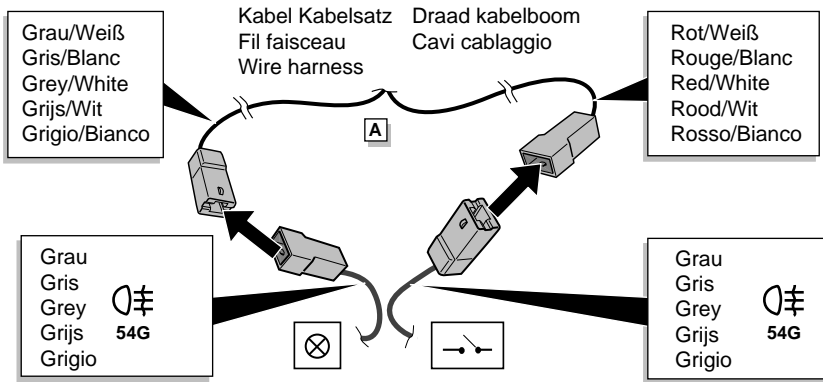
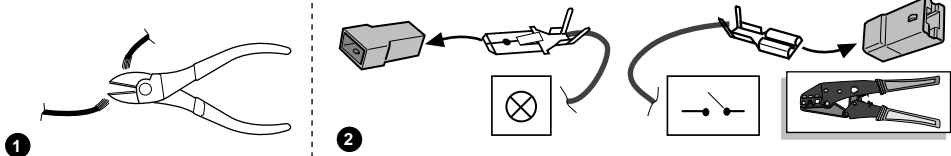
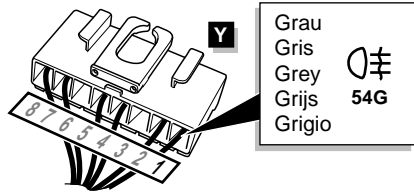

INFO

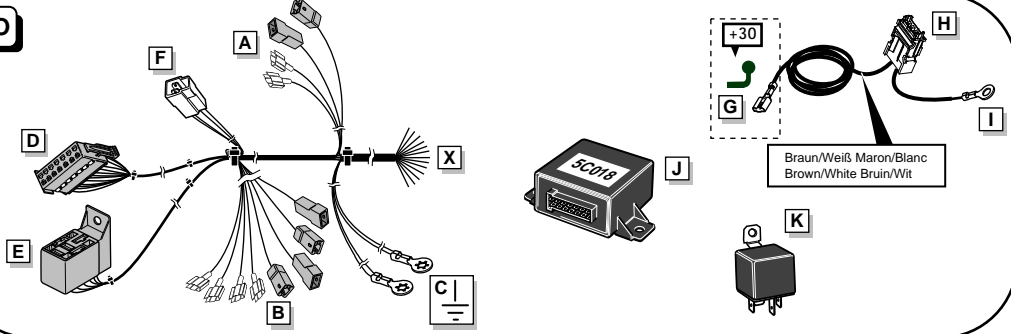

ROUTING

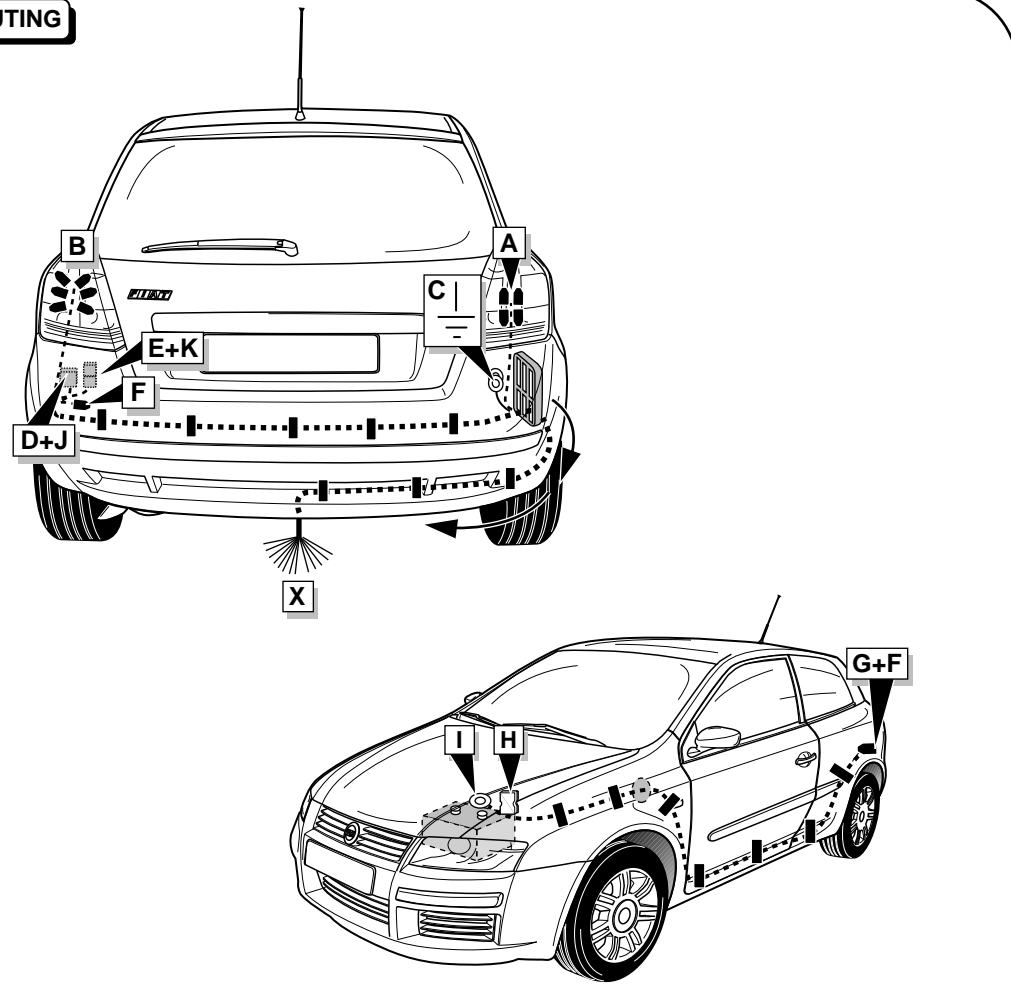

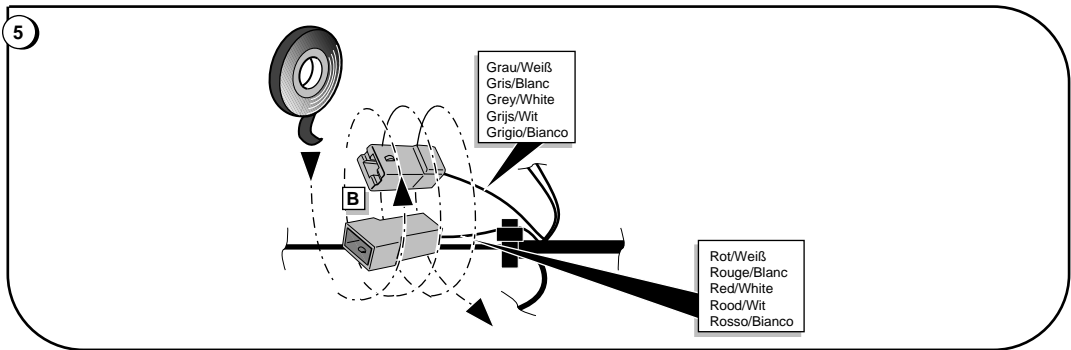
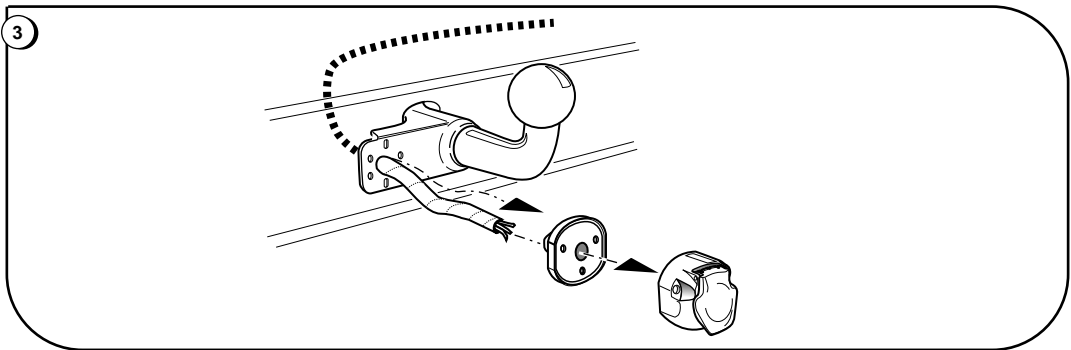

INFO Anschluß Steckdose / Connection de la prise / Socket connection / Contactdoos aansluiting / Collegamento pressa di corrente

DIN/ISO 11446		D	F	GB	NL	I	Pmax
	1/L	gelb	jaune	yellow	geel	giallo	21W
	2	blau	bleu	blue	blauw	blu	2x21W
	3/31	weiß	blanc	white	wit	bianco	
	4/R	grün	vert	green	groen	verde	21W
	5/58-R	braun	marron	brown	bruin	marrone	52W
	6/54	rot	rouge	red	rood	rosso	3x21W
	7/58-L	schwarz	noir	black	zwart	nero	52W
	8	schwarz/rot	noir/rouge	black/red	zwart/rood	nero/rosso	2x21W
	9	braun/weiß	marron/blanc	brown/white	bruin/wit	marrone/bianco	180W / 15 Amp
	10	rot	rouge	red	rood	rosso	180W / 15 Amp
	11	weiß	blanc	white	wit	bianco	
	12	rot/blau	rouge/bleu	red/blue	rood/blauw	rosso/blu	
	13	weiß	blanc	white	wit	bianco	

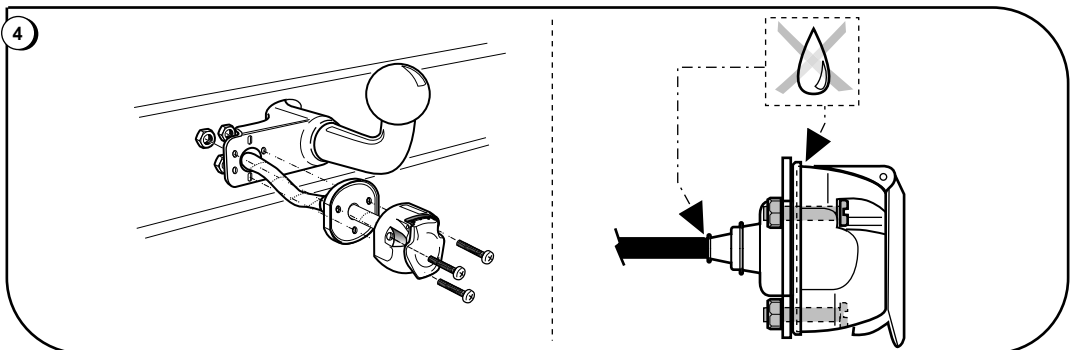

6

1 **2** **3** **4**

Kabel Fil faisceau Wire harness Draad kabelboom Cavi cablaggio	Lokalisieren Sie und überprüfen Sie Funktionen Localisez et vérifiez fonctions Locate and check functions Funcies doormeten Individui e controlli le funzioni
A Schwarz/Grün Noir/Vert Black/Green Zwart/Groen Nero/Verde	↔ → R
A Schwarz/Braun Noir/Marron Black/Brown Zwart/Bruin Nero/Marrone	↔ ☀ 58 R
B Schwarz/Rot Noir/Rouge Black/Red Zwart/Rood Nero/Rosso	↔ Reverse
B Violett/Schwarz Violet/Noir Purple/Black Paars/Zwart Viola/Nero	↔ ☀ 58 L
B Blau/Rot Bleu/Rouge Blue/Red Blauw/Rood Blu/Rosso	↔ STOP 54
B Schwarz/Gelb Noir/Jaune Black/Yellow Zwart/Geel Nero/Giallo	↔ ← L