

**Einbauanleitung Elektrosatz
Anhängervorrichtung mit 13-P Steckdose
lt. DIN/ISO Norm 11446**

**Instructions de montage du faisceau
électrique pour crochet d'attelage
conforme à la norme
DIN/ISO 11446 prise 13-P**

**Fitting instructions electric wiringkit
towbar with 13-P socket up to
DIN/ISO norm 11446**

**Montage-handleiding elektrokabelset voor
trekhaak met 13-P contactdoos
vlg. DIN/ISO norm 11446**

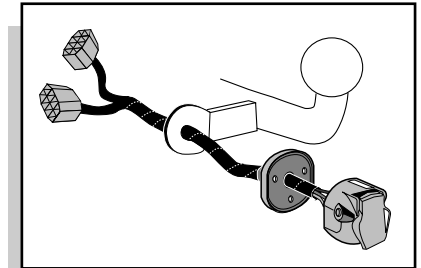

FIAT SEICENTO 1998-

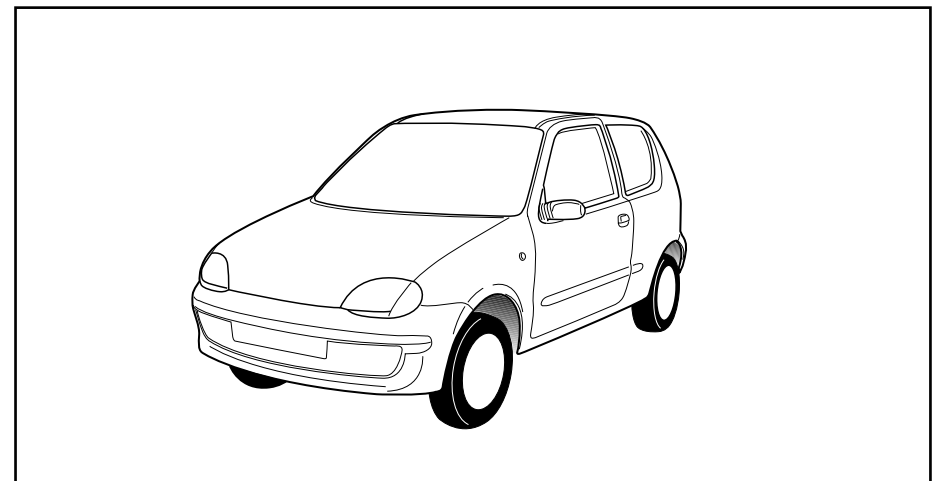

Bestel Nr.: FI-002-DB

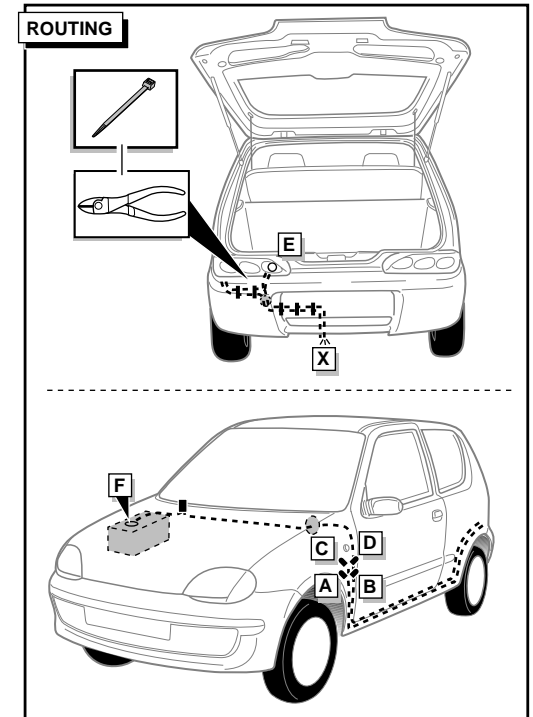
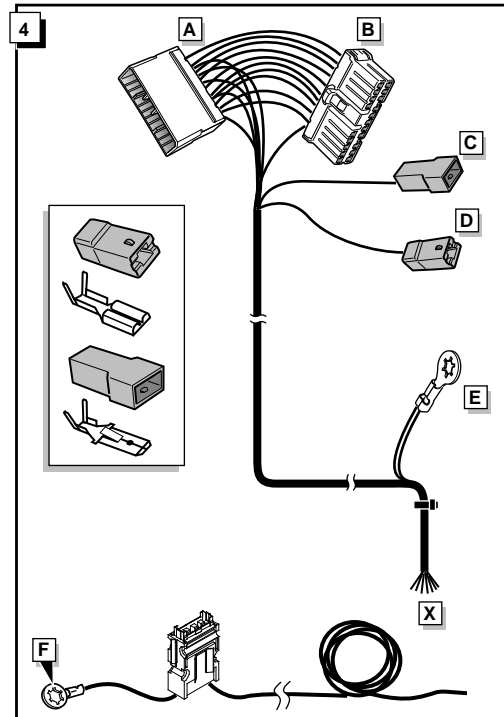
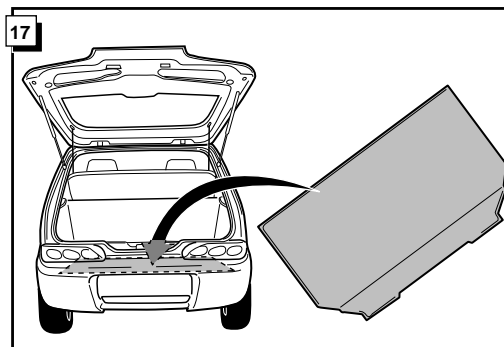
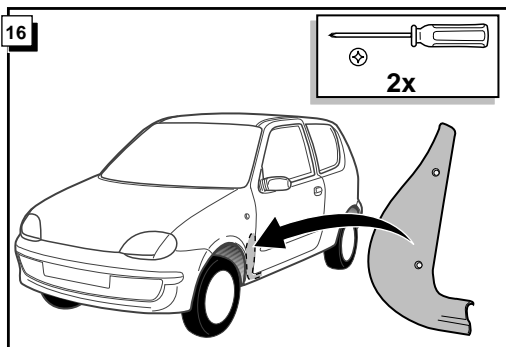
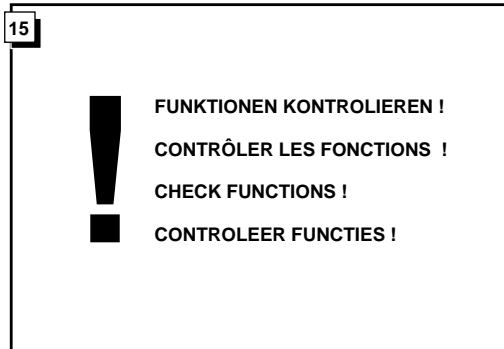
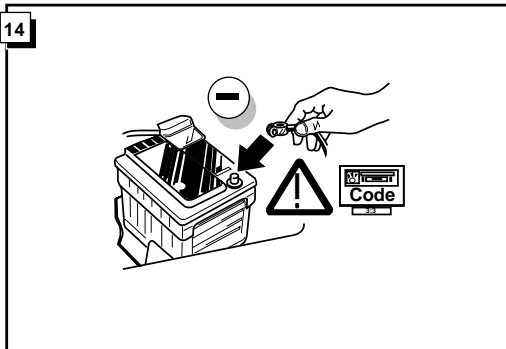
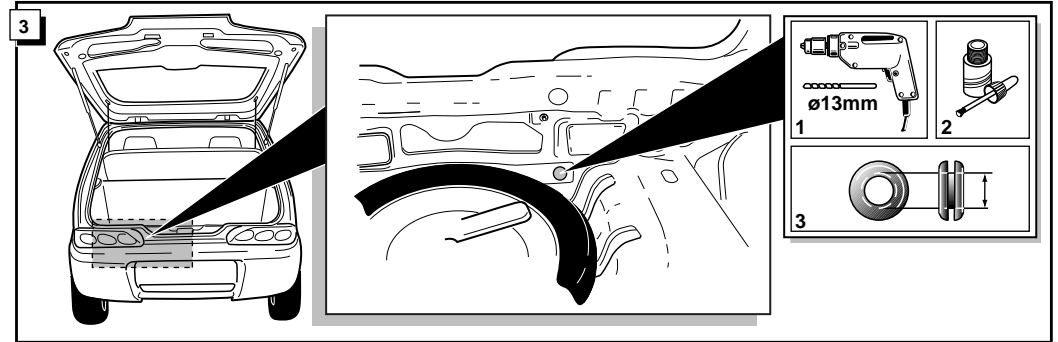
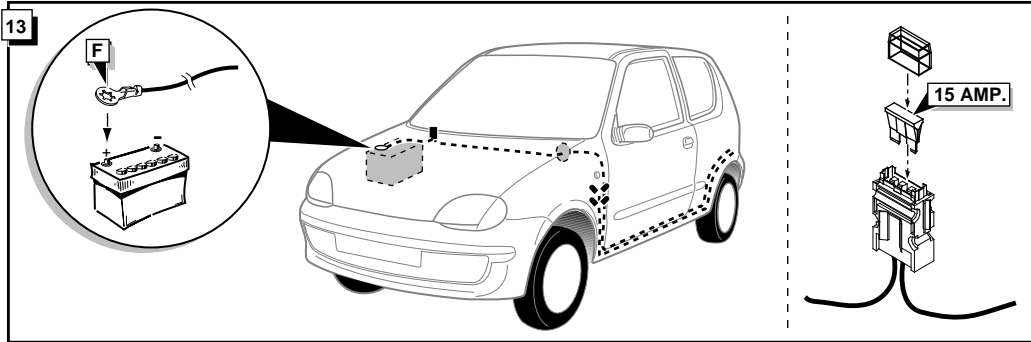
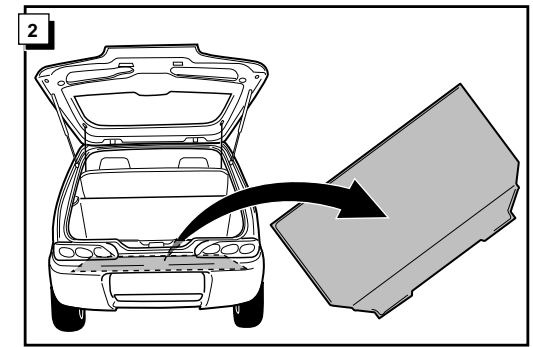
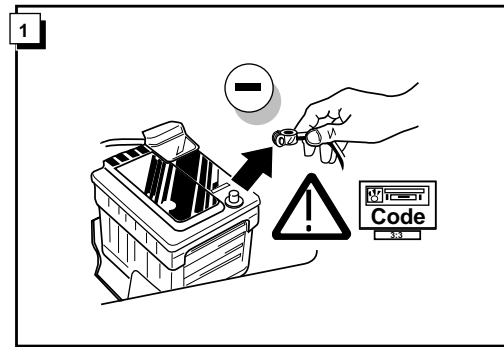
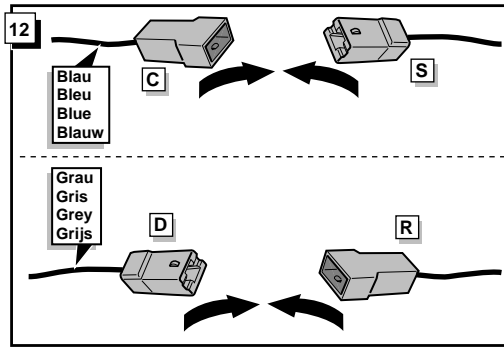
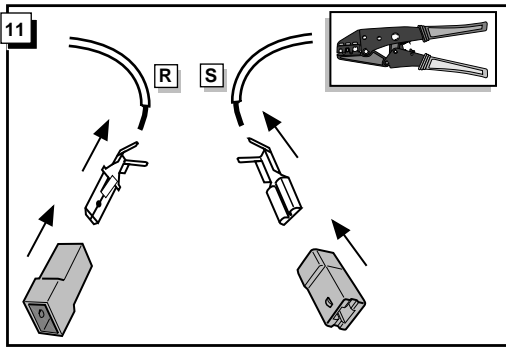

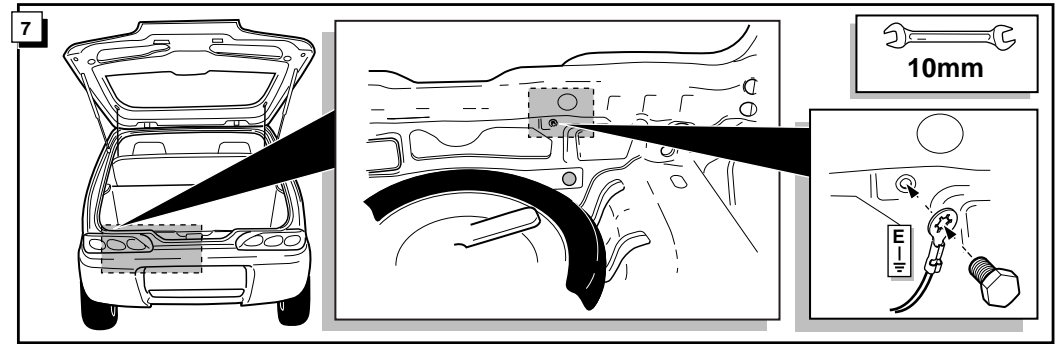
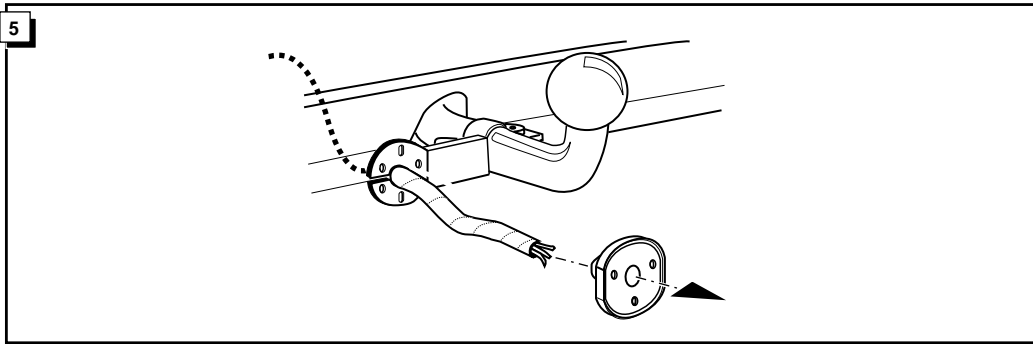

6

1

BLINKER LINKS
CLIGNOTANT GAUCHE
L.H. INDICATOR
KNIPPERLICHT LINKS

RUCKFAHR LEUCHE
PHARE DE RECOL
REVERSE LIGHT
ACHTERUITRIJ-LICHT

SCHLUßLEUCHE LINKS
FEU ARRIERE GAUCHE
L.H. REARLIGHT
ACHTERLICHT LINKS

BREMSLEUCHE
FEUX DE STOP
BRAKELIGHTS
REMFLICHTEN

STOP

BLINKER RECHTS
CLIGNOTANT DROIT
R.H. INDICATOR
KNIPPERLICHT RECHTS

SCHLUßLEUCHE RECHTS
FEU ARRIERE DROIT
R.H. REARLIGHT
ACHTERLICHT RECHTS

MASSE
MASSE
EARTH
MASSA

MASSE
MASSE
EARTH
MASSA

	D	FR	GB	NL
1/L	GELB	JAUNE	YELLOW	GEEL
2	BLAU	BLEU	BLUE	BLAUW
2a	GRAU	GRIS	GREY	GRIJS
3/31	WEIß	BLANC	WHITE	WIT
4/R	GRÜN	VERT	GREEN	GROEN
5/58-R	BRAUN	MARRON	BROWN	BRUIN
6/54	ROT	ROUGE	RED	ROOD
7/58-L	SCHWARZ	NOIR	BLACK	ZWART
8	SCHW/RT	NO/RO	BL/RD	ZW/RD
9	BR/WE	MAR/BLA	BR/WHI	BR/WI
10				
11				
12				
13	WEIß	BLANC	WHITE	WIT

2

