

Citroën C4 Picasso 10-2006- Fog lamp disconnection



Partnr.: CT-037-ZZ

(DE) Ergänzungssatz

(FR) Set d'extension

(NL) Uitbreidingsset

(GB) Extension kit

(ES) Equipo de extensión

(IT) Set di ampliamento

(SE) Förlängningsatts

(CZ) Prodlužovací souprava

(DK) Forlængelsesæt

(FI) Lisäsarja

(GR) εξάρτηση επέκτασης

(NO) Påbyggingssett

(PL) Zestaw rozszerzający

(DE) - Wir weisen ausdrücklich darauf hin, dass eine unsachgemäße und nicht in einer Fachwerkstatt durchgeführte Montage einen Verzicht auf Entschädigung jeglicher Art insbesondere bezüglich des Produkthaftpflichtrechts zur Folge hat

(FR) - Il est expressément prévu qu' on ne saurait se prévaloir d'un quelconque préjudice contractuel ou rédhibitoire si le montage avait été fait en dépit des dites instructions ou dans un garage ne disposant pas des équipements adéquats.

(NL) - Wij wijzen er met nadruk op, dat ondeskundige en niet door een vakkundige werkplaats uitgevoerde montage tot gevolg heeft dat daardoor ieder recht op schadevergoeding, ook op wettelijke aansprakelijkheid inzake producten, vervalt.

(GB) - We would expressly point out that assembly not carried out properly by a competent installer will result in cancellation of any right to damage compensation, in particular those arising by virtue of the product liability act.

(ES) - El montaje inapropiado y efectuado por personal no cualificado originará la pérdida de todo derecho a indemnización o la expiración de toda responsabilidad civil con respecto al producto.

(IT) - Sottolineiamo espressamente che un montaggio inadeguato ed eseguito da un'officina non specializzata ha come conseguenza il decadere di qualsiasi diritto al risarcimento danni, nonché alla responsabilità legale relativa ai prodotti.

(SE) - Vi påpekar med eftertryck att all rätt till skadeersättning och all laglig ansvarighet förfaller om monteringen inte har utförts på rätt sätt och av en professionell verkstad.

(CZ) - Výslovně zdůrazňujeme, že jakákoli montáž, která není provedená ve specializované dílně, má za následek odvolání nároků na kompenzaci jakéhokoli druhu, obzvláště vyplývajících ze zákona o odpovědnosti za způsobené škody.

(DK) - Vi ønsker at gøre udtrykkeligt opmærksom på at forkert samling, der ikke er udført af et specialiseret værksted, resulterer i bortfaldelse af kompenseringskrav af alle slags, i særdeles krav der måtte opstå omkring det lovpligtige ansvar.

(FI) - Korostamme, että kaikki oikeudet vahinkokorvaukseen kuten myös valmistajan laillinen vastuu raukeavat, mikäli asennusta ei ole toteutettu oikealla tavalla eikä ammattitaitoisen asiantuntijan toimesta.

(GR) - Επισημαίνουμε κατηγορηματικά ότι οποιαδήποτε εσφαλμένη συναρμολόγηση, η οποία δεν έχει πραγματοποιηθεί ειδικό εργαστήριο θα οδηγήσει σε απονοίηση των αξιώσεων επιβολής αποζημιώσεων οποιαδήποτε είδους, ειδικά όσα προκύπτουν από το νόμο ευθύνης προϊόντων.

(NO) - Vi påpeker ettertrykkelig at all rett til skadeerstatning og rettslig ansvar forfaller dersom monteringen ikke er blitt utført på riktig måte og av et profesjonelt verksted.

(PL) - Chcielibyśmy wyraźnie zaznaczyć, iż wszelki nieprawidłowy montaż, który nie jest wykonywany w specjalistycznym warsztacie pociąga za sobą utratę możliwości dochodzenia wszelkiego typu roszczeń, w szczególności tych wynikających z odpowiedzialności producenta za swój produkt.

- Technische Änderungen vorbehalten.

- Sous réserve de modifications techniques.

- Technische wijzigingen voorbehouden.

- Contents of these kits and their fitting manuals are subject to alteration without notice, please ensure that these instructions are read and fully understood before commencing installation.

- Nos reservamos el derecho a efectuar modificaciones técnicas.

- Ci si riserva il diritto di apportare modifiche tecniche.

- Tekniska ändringar förbehålles.

- Změny mohou být provedeny bez oznámení.

- Kan ændres uden varsel.

- Oikeus teknisiin muutoksiin ilman erillistä huomautusta pidätetään.

- Μπορεί να τροποποιηθεί χωρίς προηγούμενη ειδοποίηση.

- Tekniske endringer forbeholdes.

- Podlega zmianom bez powiadomienia.

Teilliste

Liste de pieces

Onderdelenlijst

Part list

Lista de componentes

Elenco componenti

Dellista

Seznam dílů

Del-liste

Osaluettelo

Κατάλογος εξαρτημάτων

Delliste

Lista części

DE

FR

NL

GB

ES

IT

SE

CZ

DK

FI

GR

NO

PL

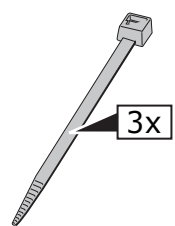
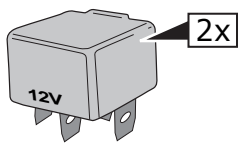
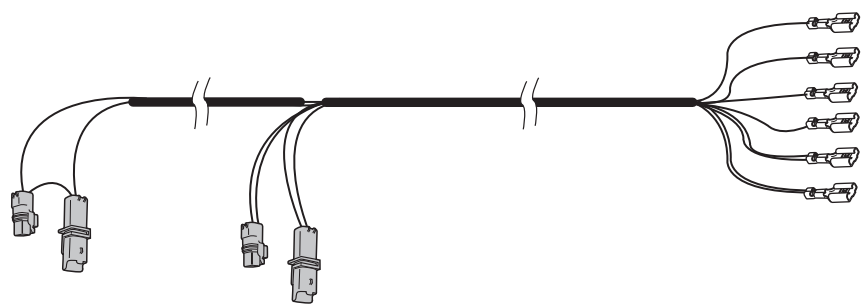
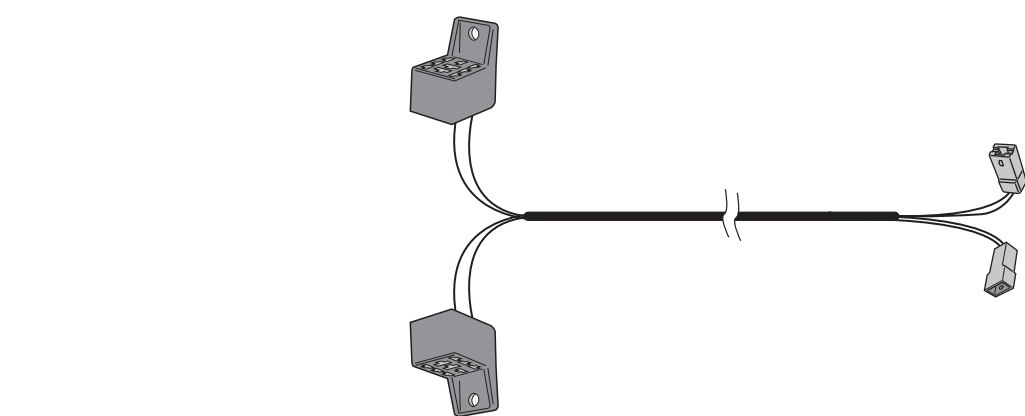
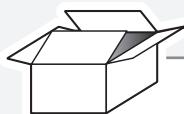

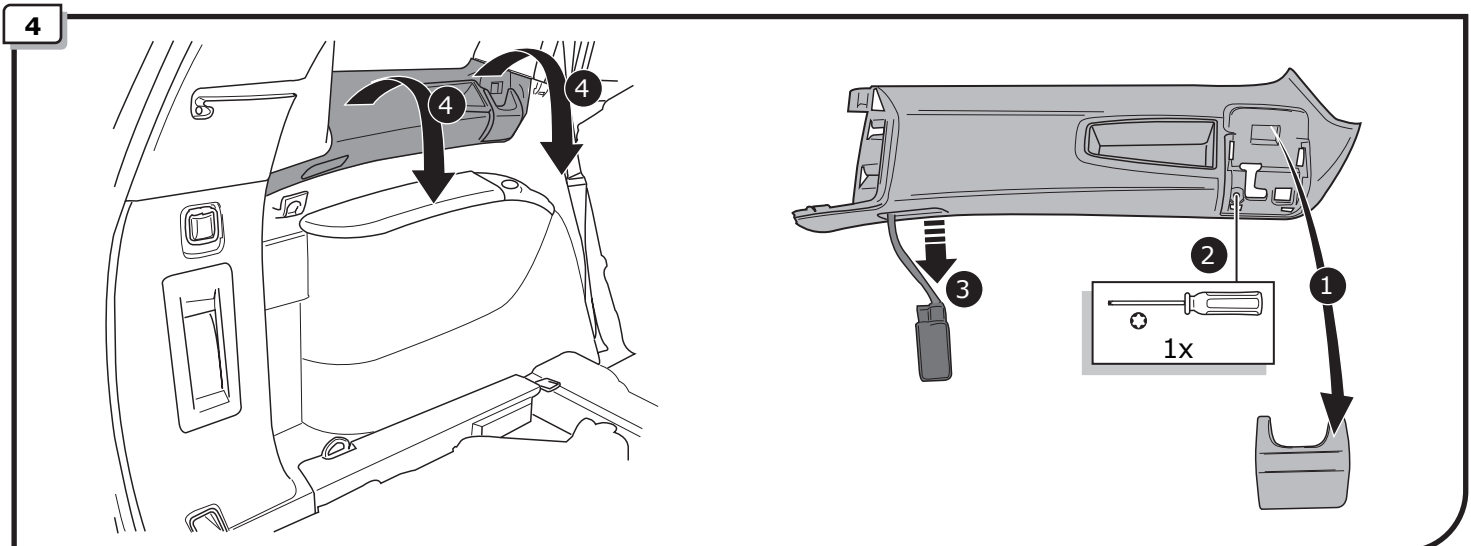
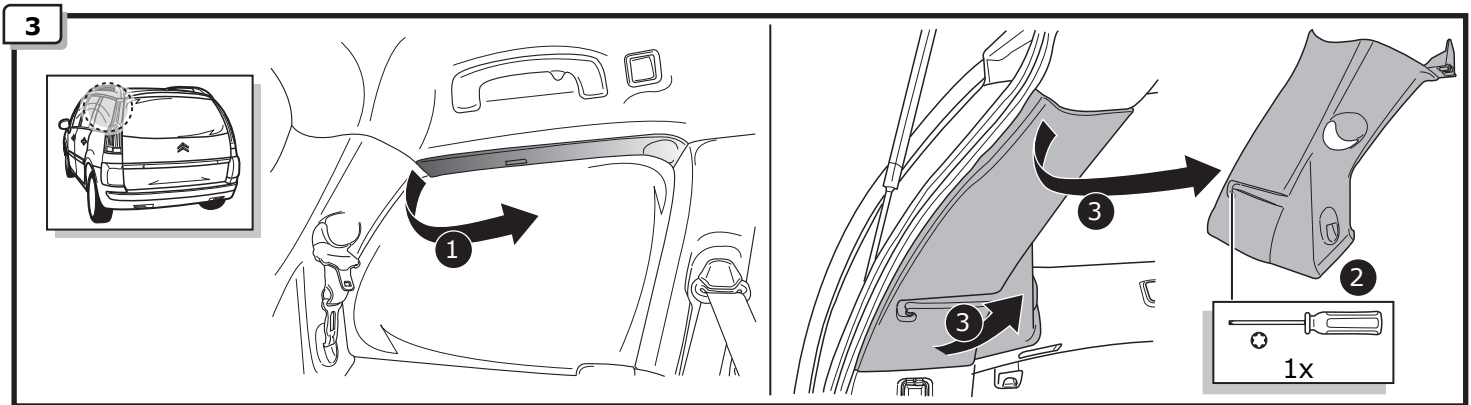
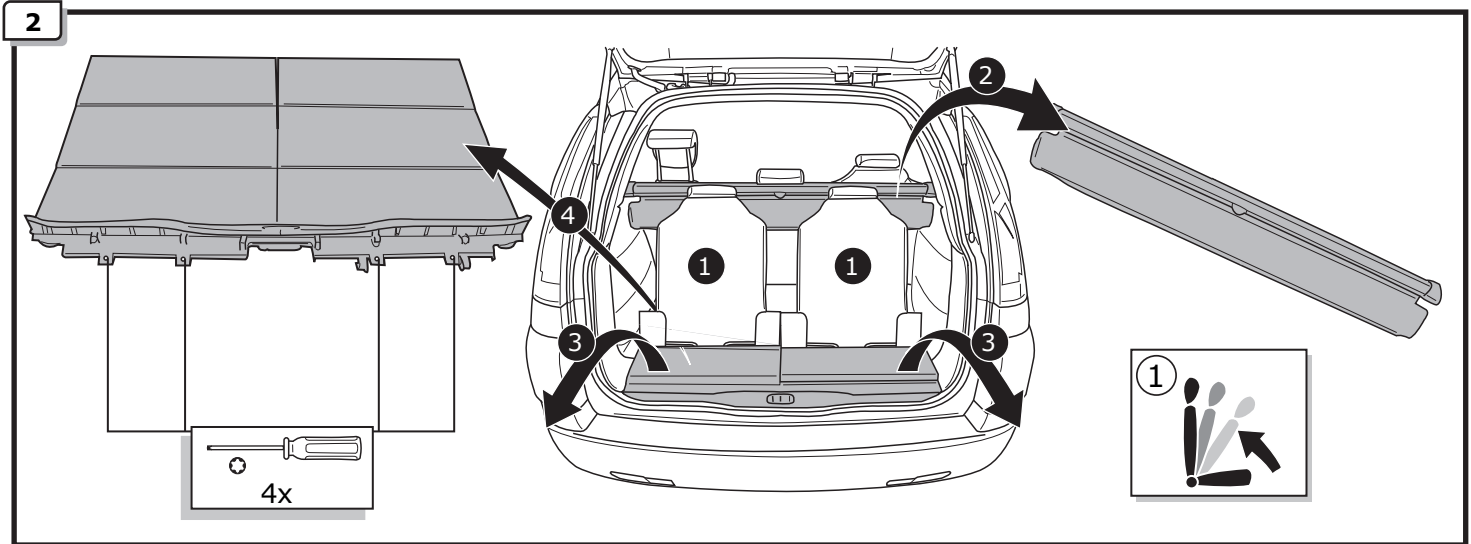
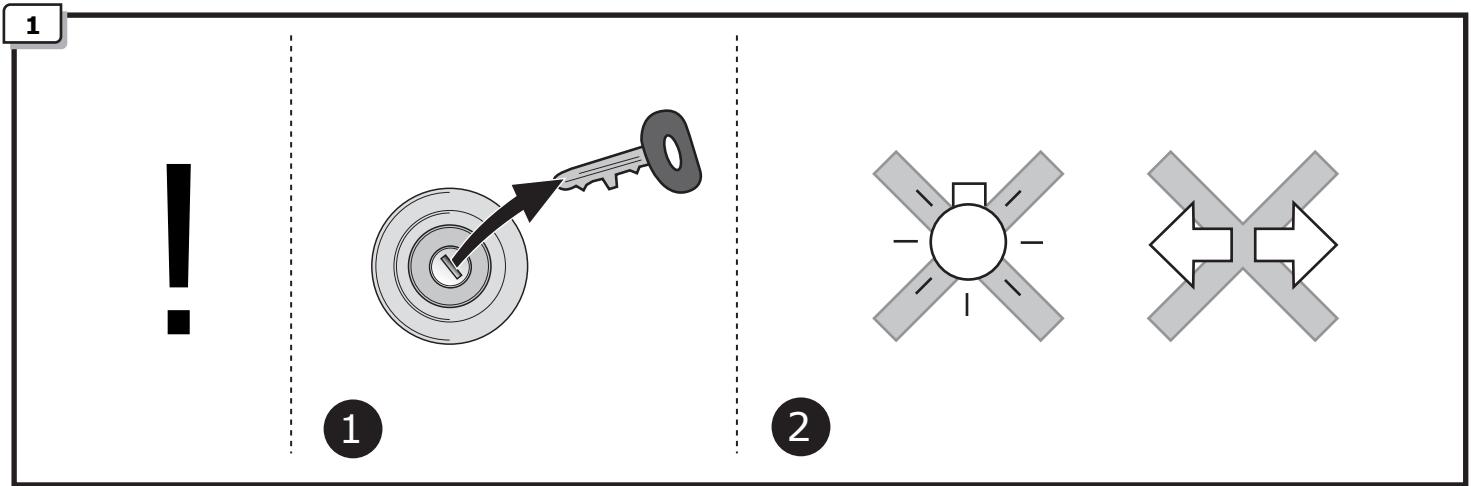

5

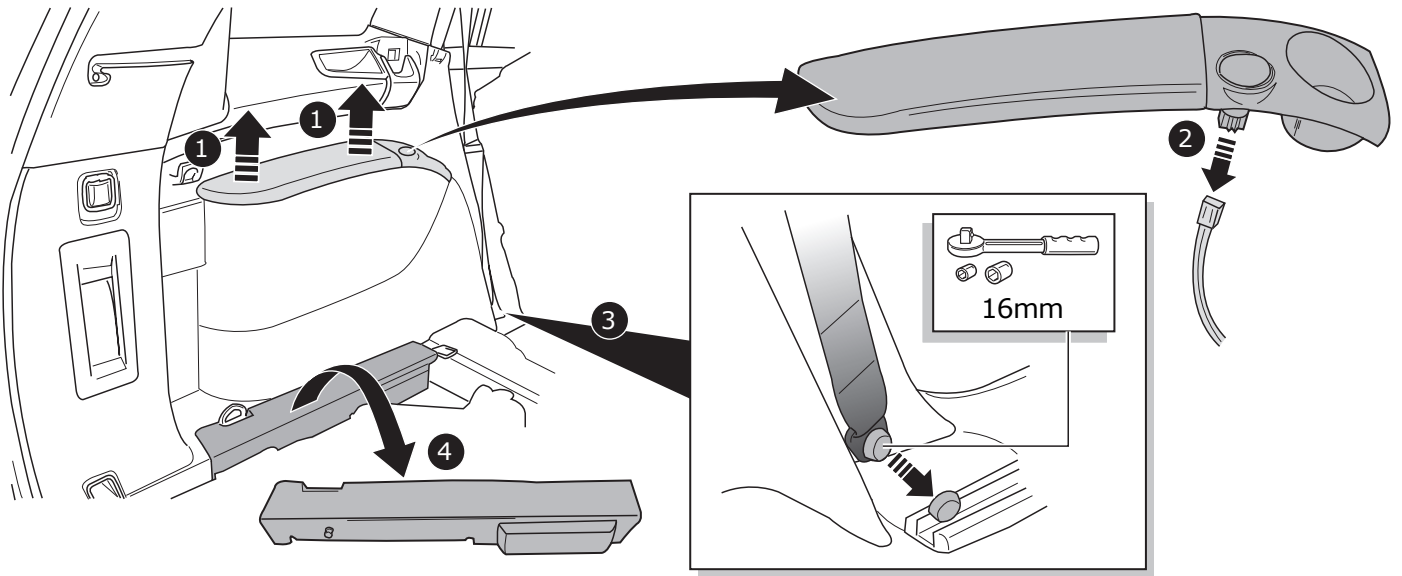

6

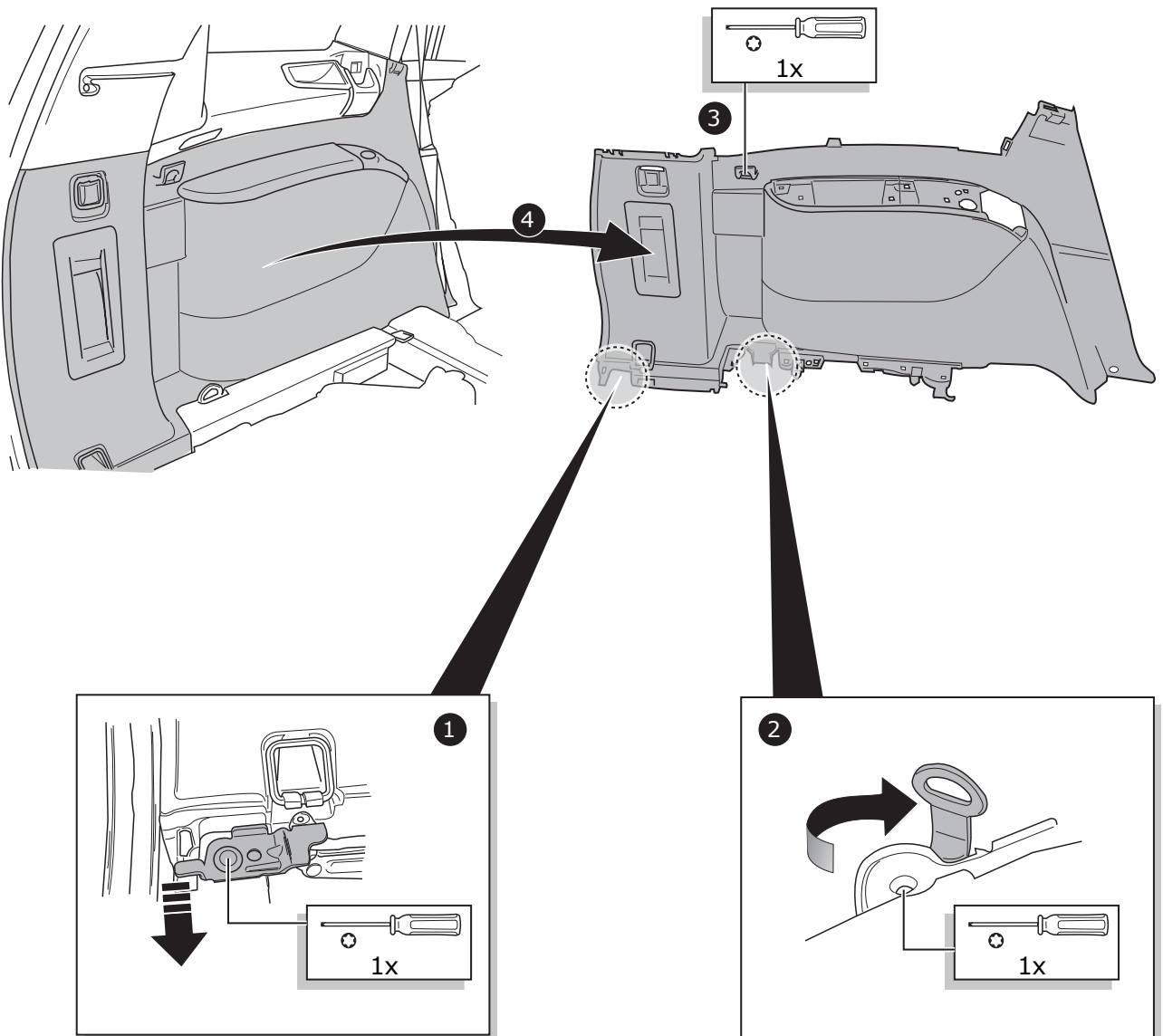

INFO

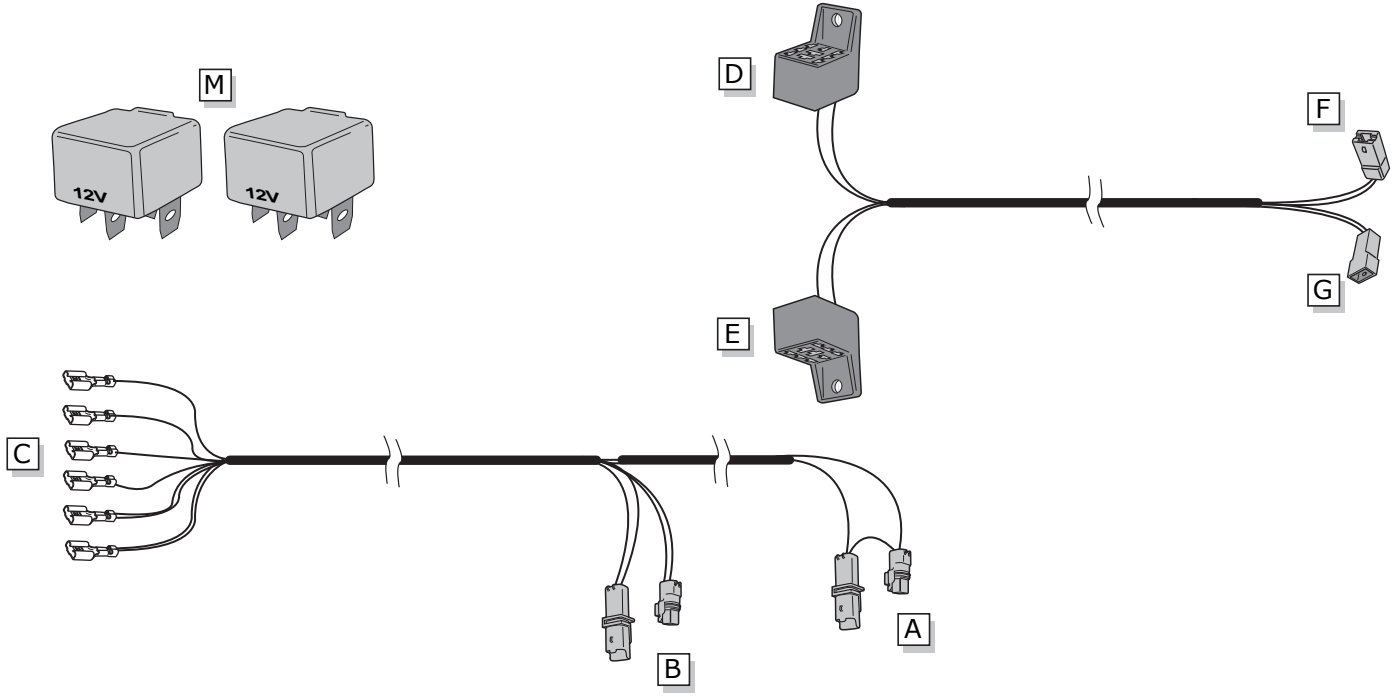

ROUTING

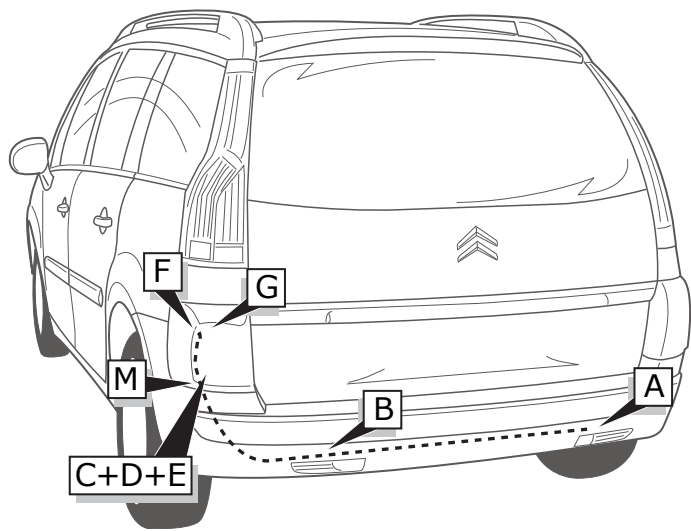

7

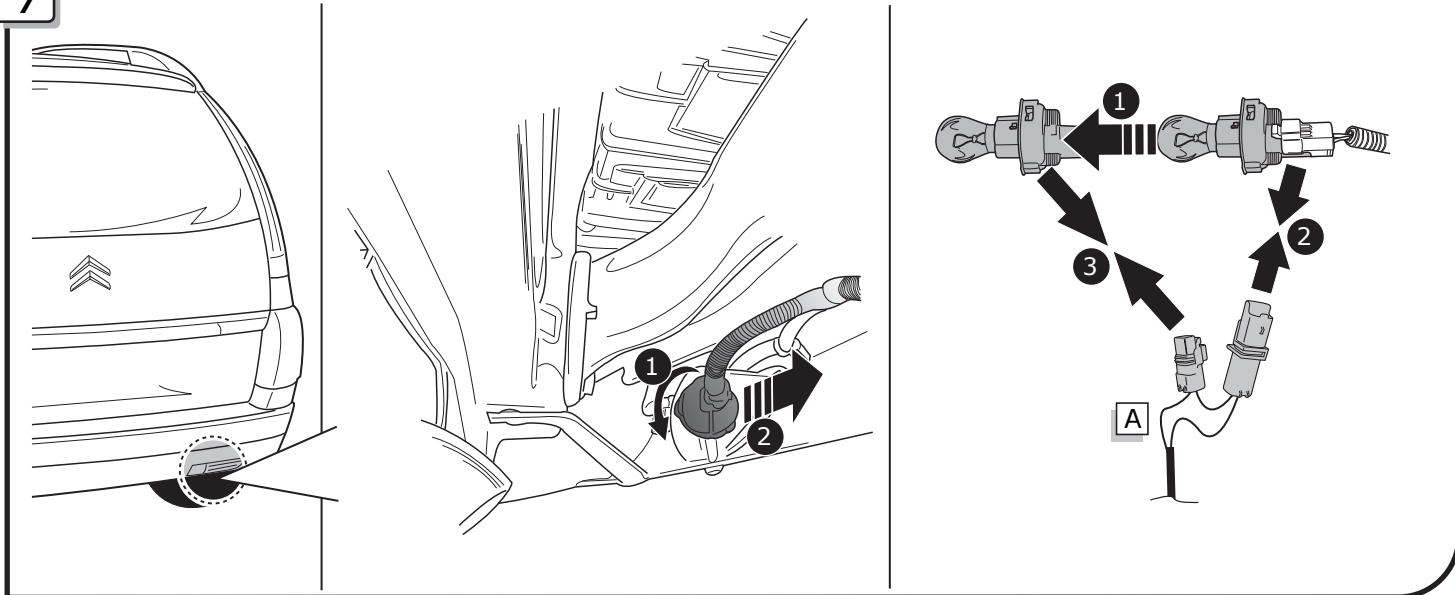

8

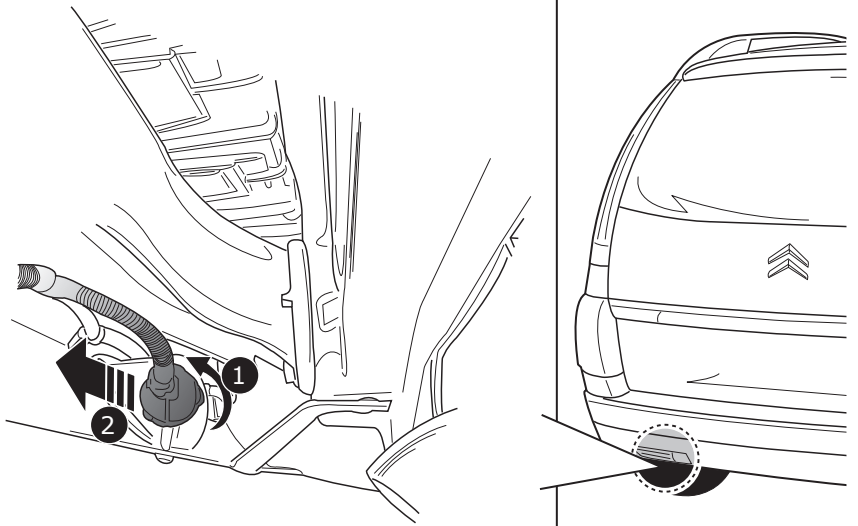
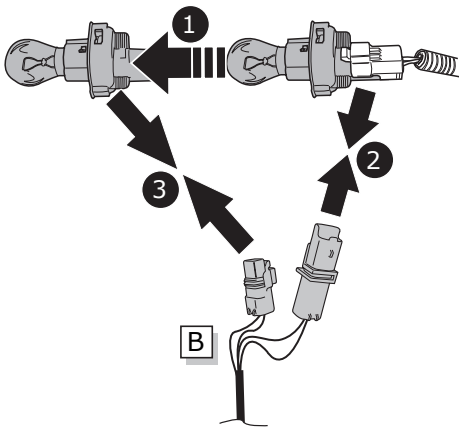

9

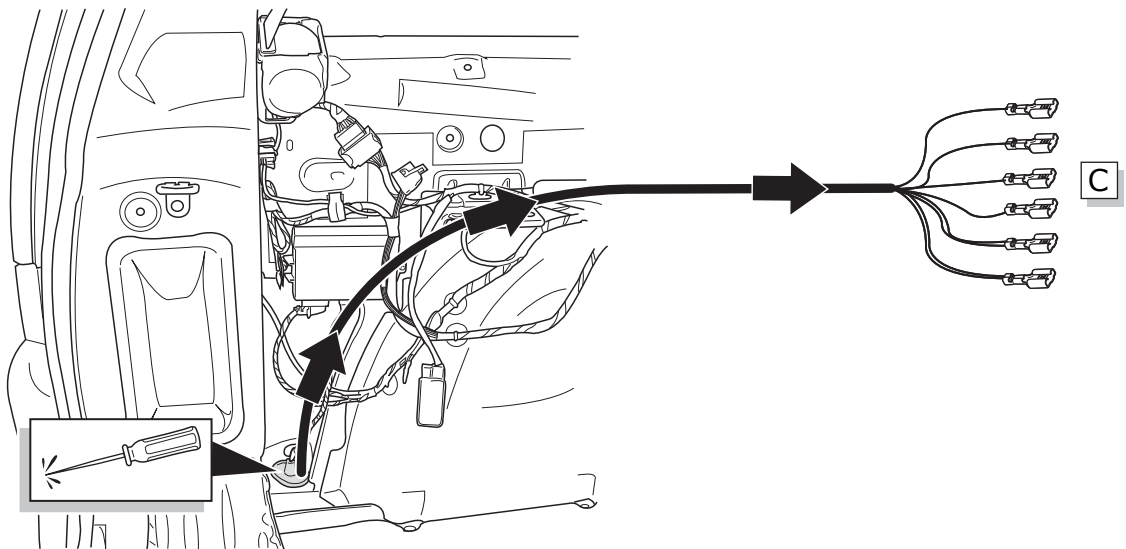

10

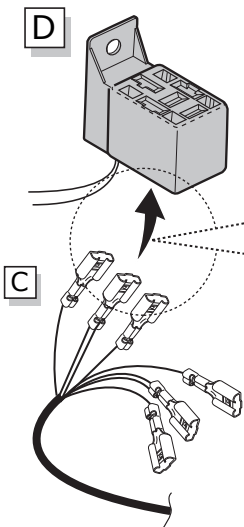

DE	Blau/Weiß	CZ	Modro/Bílá
FR	Blue/Blanc	DK	Blå/Hvid
NL	Blauw/Wit	FI	Sininen/Valkoinen
GB	Blue/White	GR	Μπλε/Λευκό
ES	Azul/Blanco	NO	Blå/Hvit
IT	Blu/Bianco	PL	Niebieski/Biały
SE	Blå/Vit		

DE	Blau	CZ	Modrá
FR	Blue	DK	Blå
NL	Blauw	FI	Sininen
GB	Blue	GR	Μπλε
ES	Azul	NO	Blå
IT	Blu	PL	Niebieski
SE	Blå		

DE	Weiß	CZ	Bílá
FR	Blanc	DK	Hvid
NL	Wit	FI	Valkoinen
GB	White	GR	Λευκό
ES	Blanco	NO	Hvit
IT	Bianco	PL	Biały
SE	Vit		

DE	Rot/Gelb	CZ	Červená/Žlutá
FR	Rouge/Jaune	DK	Rød/Gul
NL	Rood/Geel	FI	Punainen/Keltainen
GB	Red/Yellow	GR	Κόκκινο/Κίτρινο
ES	Rojo/Amarillo	NO	Rød/Gul
IT	Rosso/Giallo	PL	Czerwony/Żółty
SE	Röd/Gul		

DE	Grau	CZ	Šedá
FR	Gris	DK	Grå
NL	Grijs	FI	Harmaa
GB	Grey	GR	Γκρι
ES	Gris	NO	Grå
IT	Grigio	PL	Szary
SE	Grå		

11

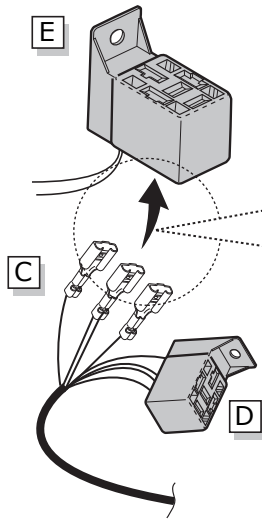

DE	Blau/Weiß	CZ	Modro/Bílá
FR	Blue/Blanc	DK	Blå/Hvid
NL	Blauw/Wit	FI	Sininen/Valkoinen
GB	Blue/White	GR	Μπλε/Λευκό
ES	Azul/Blanco	NO	Blå/Hvit
IT	Blu/Bianco	PL	Niebieski/Biały
SE	Blå/Vit		

DE	Blau	CZ	Modrá
FR	Blue	DK	Blå
NL	Blauw	FI	Sininen
GB	Blue	GR	Μπλε
ES	Azul	NO	Blå
IT	Blu	PL	Niebieski
SE	Blå		

DE	Weiß	CZ	Bílá
FR	Blanc	DK	Hvid
NL	Wit	FI	Valkoinen
GB	White	GR	Λευκό
ES	Blanco	NO	Hvit
IT	Bianco	PL	Biały
SE	Vit		

DE	Rot/Weiß	CZ	Červeno/Bílá
FR	Rouge/Blanc	DK	Rød/Hvid
NL	Rood/Wit	FI	Punainen/Valkoinen
GB	Red/White	GR	Κόκκινο/Λευκό
ES	Rojo/Blanco	NO	Rød/Hvit
IT	Rosso/Bianco	PL	Czerwony/Biały
SE	Röd/Vit		

DE	Grau/Weiß	CZ	Šedo/Bílá
FR	Gris/Blanc	DK	Grå/Hvid
NL	Grijs/Wit	FI	Harmaa/Valkoinen
GB	Grey/White	GR	Γκρι/Λευκό
ES	Gris/Blanco	NO	Grå/Hvit
IT	Grigio/Bianco	PL	Szary/Biały
SE	Grå/Vit		

12

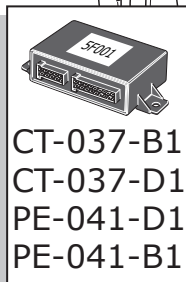
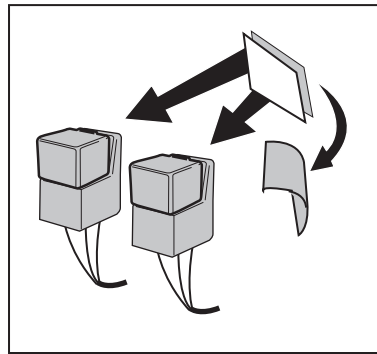
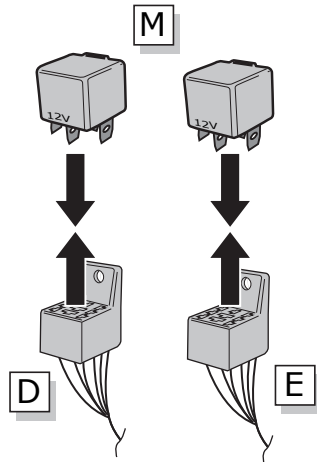

CT-037-B1
CT-037-D1
PE-041-D1
PE-041-B1

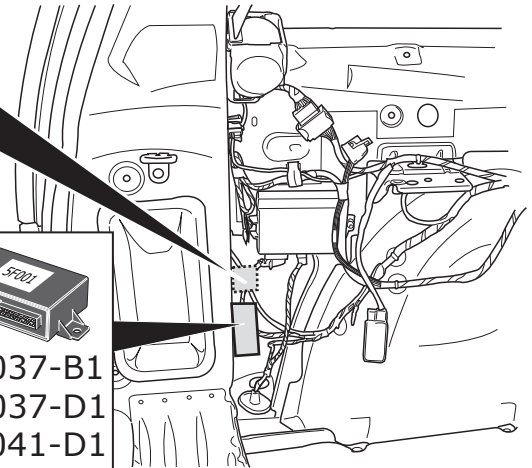

13

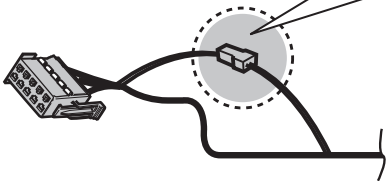

DE	Blau	CZ	Modrá
FR	Blue	DK	Blå
NL	Blauw	FI	Sininen
GB	Blue	GR	Μπλε
ES	Azul	NO	Blå
IT	Blu	PL	Niebieski
SE	Blå		

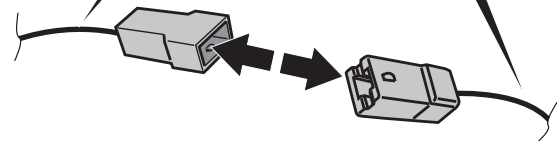

14

CT-037-B1
CT-037-D1
PE-041-D1
PE-041-B1

DE	Blau	CZ	Modrá
FR	Blue	DK	Blaå
NL	Blauw	FI	Sininen
GB	Blue	GR	Mnλε
ES	Azul	NO	Blå
IT	Blu	PL	Niebieski
SE	Blå		

CT-037-B1
CT-037-D1
PE-041-D1
PE-041-B1

F

G

15

- DE** FUNKTIONEN KONTROLLIEREN MIT EINEM PRÜFGERÄT MIT WIDERSTAND ODER MIT LEUCHTEN MIT DER GENAUEN WATTZAHL!
- FR** CONTRÔLER LES FONCTIONS AVEC UNE BOÎTE DE TEST AVEC DE LA CHARGE OU DES LAMPES AVEC LA QUANTITÉ CORRECTE DE WATT!
- NL** CONTROLEER FUNCTIES MET EEN TESTER MET BELASTING OF LAMPEN MET DE JUISTE WATTAGE!
- GB** TEST ALL CIRCUIT FUNCTIONS WITH A TESTBOX WITH THE CORRECT POWER LOAD FOR EACH UNIT. A TESTBOX ON WHICH ONLY LEDs ARE USED CAN NOT BE USED IN THIS CASE
- ES** ¡CONTROLAR FUNCIONES CON UN TESTER CON CARGA O LUCES CON EL CORRECTO WATTAJE!
- IT** CONTROLLA FUNZIONI CON UN TESTER CON CARICO O LAMPADE DEL GIUSTO WATT-TAGGIO!
- SE** KONTROLLERA FUNKTIONERNA MED EN TESTARE MED BELASTNING ELLER LAMPOR MED RÄTT WATT-VÄRDE!
- CZ** OVĚŘTE FUNKCE POMOČÍ TESTOVACÍHO BOXU NEBO SVĚTEL S PŘÍSLUŠNÝM VÝKONEM!
- DK** CHECK FUNKTIONERNE MED EN TESTBOKS, MED BELASTNING ELLER MED LYGTER MED DET KORREKTE ANTAL WATT!
- FI** TARKISTA TOIMINNOT KÄYTTÄMÄLLÄ TESTILAITE, JOSSA ON OIKEATEHOINEN KUORMITUS TAI OIKEATEHOISET LAMPUT!
- GR** ΕΛΕΓΞΤΕ ΤΙΣ ΛΕΙΤΟΥΡΓΙΕΣ ΜΕ ΉΝΑ ΚΙΒΩΤΙΟ ΔΟΚΙΜΗΣ ΜΕ ΦΟΡΤΙΟ Ή ΛΑΜΠΙΡΕΣ ΣΩΣΤΗΣ ΠΟΣΟΤΗΤΑΣ ΒΑΤ!
- NO** KONTROLER FUNKSJONENE MED EN TESTER MED BELASTNING ELLER LYSPÆRER MED RIKTIG WATTVERDI!
- PL** SPRAWDŹ FUNKCJE UŻYWAJĄC SKRZYŃKI TESTOWEJ Z OBCIĄŻENIEM LUB PODŁĄCZONYMI ŻARÓWKAMI O ODPOWIEDNIEJ MOCY!

16

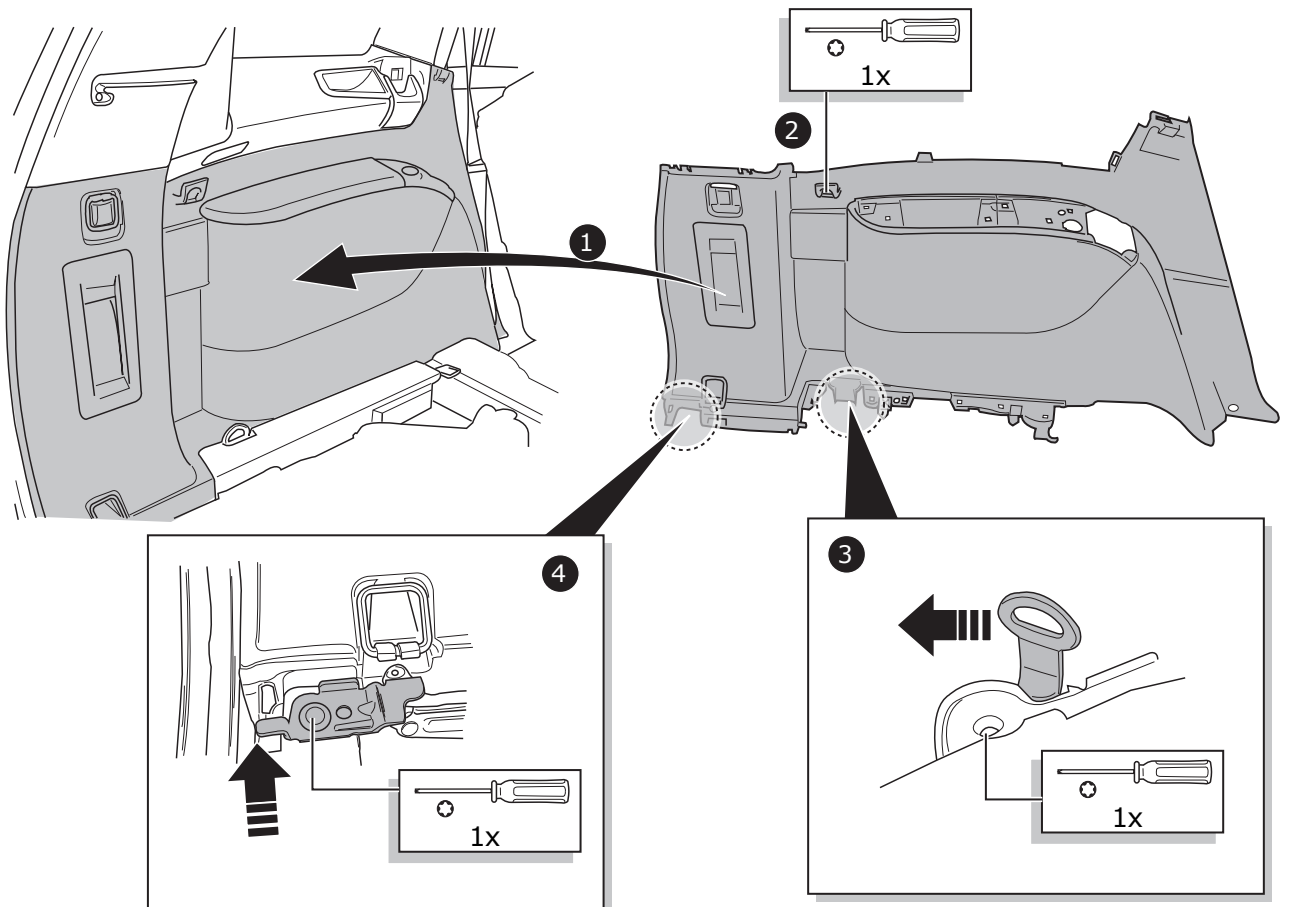

17

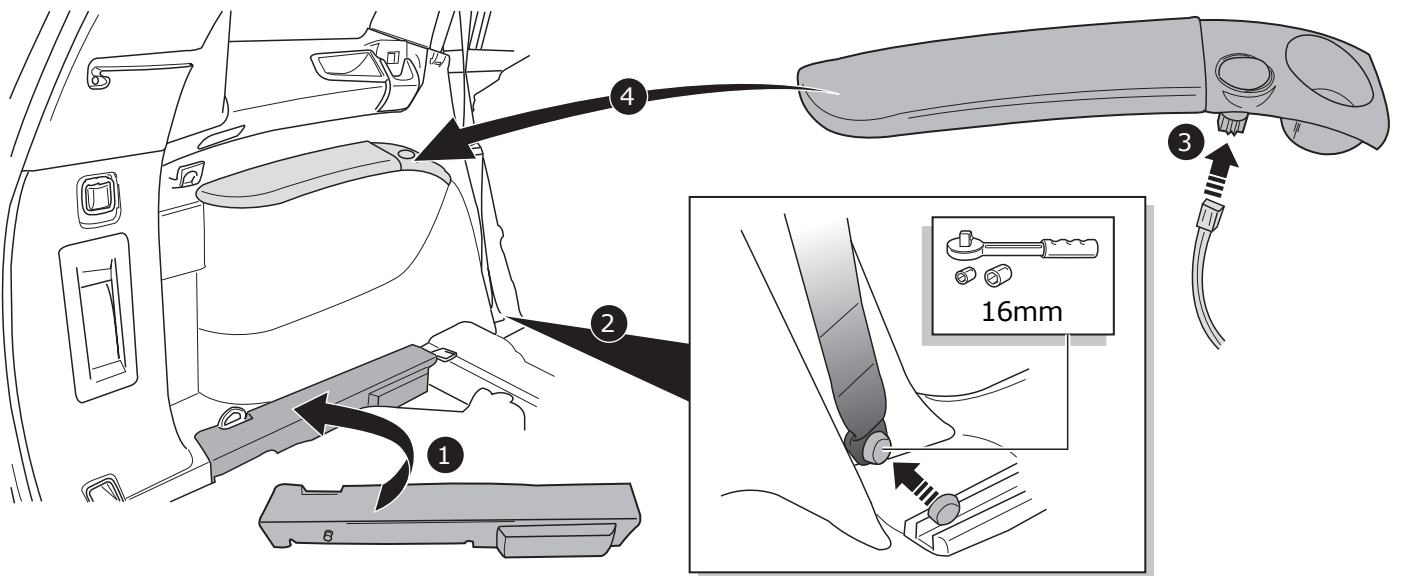

18

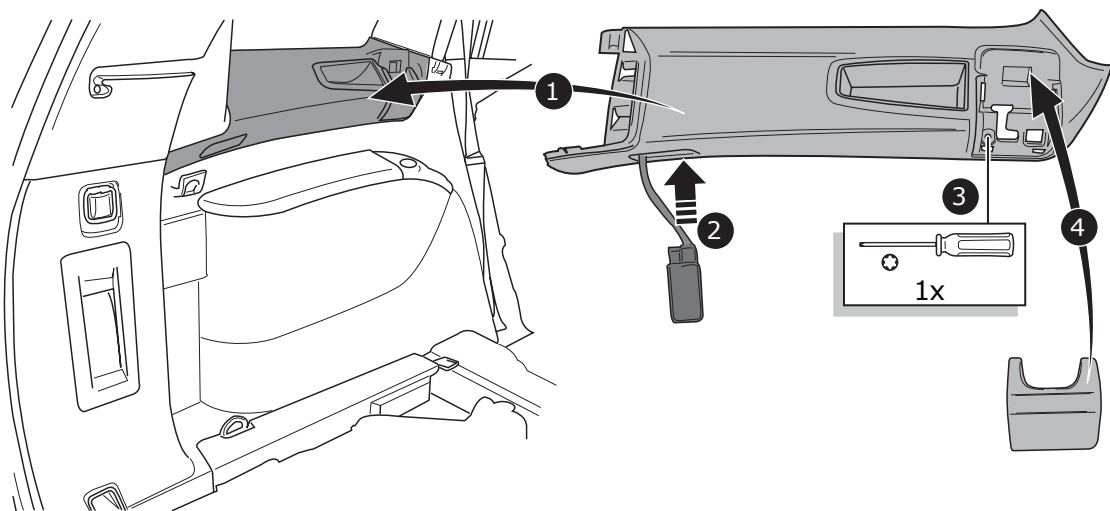

19

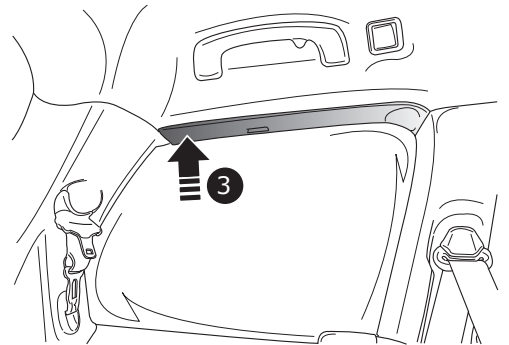
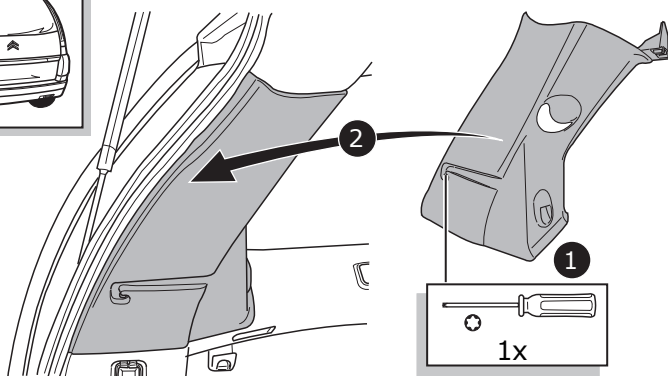
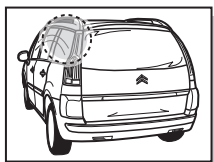

20

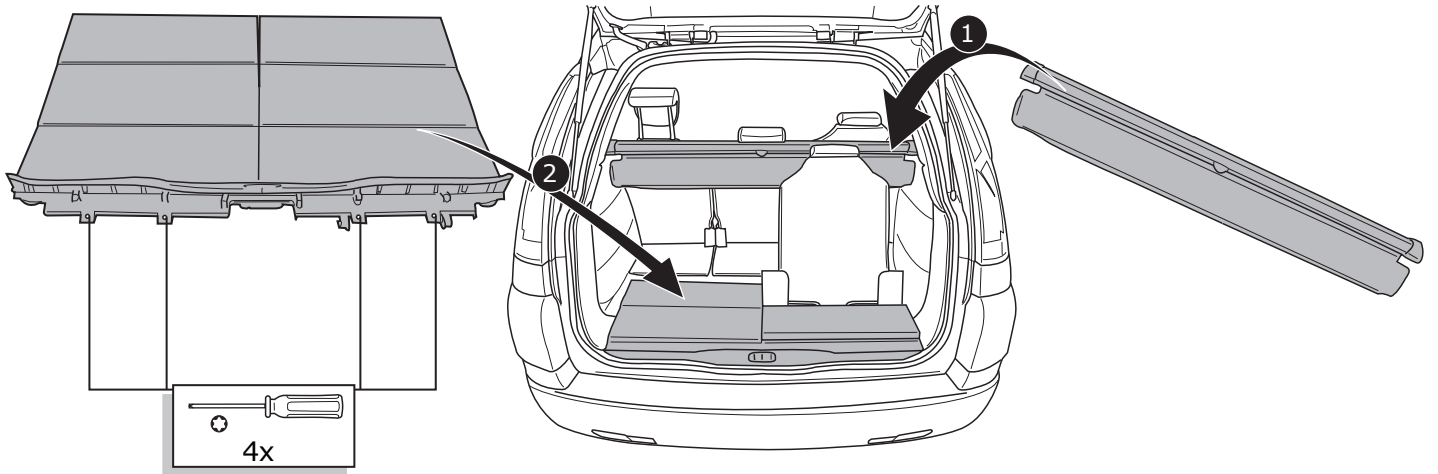

21

- ⒹE Gebrauchsanleitung.
- ⒻR Mode d'emploi.
- ⒶL Gebruikershandleiding.
- ⒼB User guide.
- ⒺS Guía del usuario.
- ⒾT Manuale di istruzioni.
- ⒺE Bruksanvisning.
- ⒸZ Uživatelská příručka.
- ⒹK Brugervejledning.
- ⒻI Käyttöohjeet.
- ⒸR Οδηγός χρήστη.
- ⒶO Brukerveiledning.
- ⒶL Instrukcja obsługi.

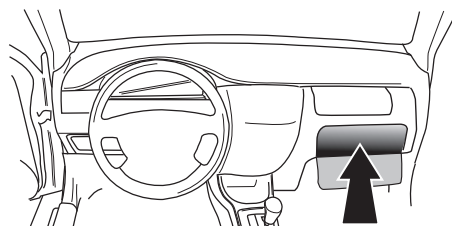

00800
CALL2ECS
22 55 23 27

09.00 - 18.00
 Monday - Friday
www.ecs-electronics.nl