

**Einbauanleitung Elektrosatz  
Anhängervorrichtung mit 12-N Steckdose  
lt. DIN/ISO Norm 1724**

**Instructions de montage du faisceau  
électrique pour crochet d'attelage  
conforme à la norme  
DIN/ISO 1724 prise 12-N**

**Fitting instructions electric wiringkit  
towbar with 12-N socket up to  
DIN/ISO norm 1724**

**Montage-handleiding elektrokabelset voor  
trekhaak met 12-N contactdoos  
vlg. DIN/ISO norm 1724**

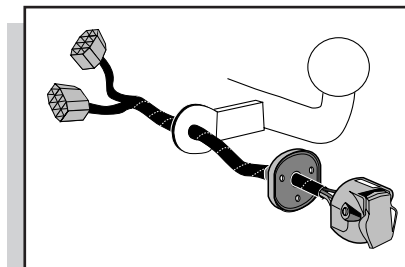

**OPEL OMEGA SEDAN Model 2000 11/1999-  
OPEL OMEGA STATION Model 2000 11/1999-**

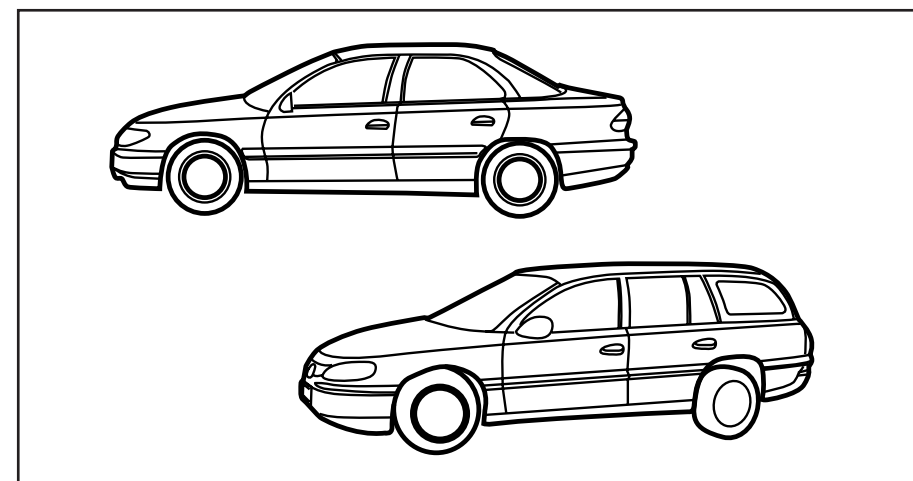

Bestel Nr.: OP-016-BL

\* Teilliste

\* Liste de pieces

\* Part list

\* Onderdelenlijst

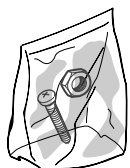
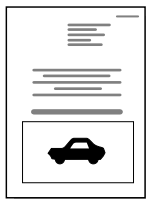
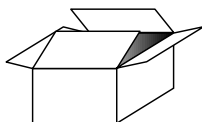

OMEGA

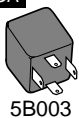

5B003

Das Relais muß einzeln bestellt werden.  
Le relais doit être commander séparément.  
The relay has to be ordered seperately.  
Het relais moet apart besteld worden.

ZAFIRA

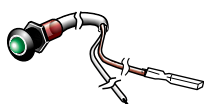

ASTRA

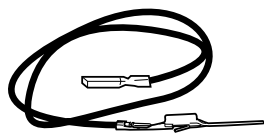

VECTRA / OMEGA

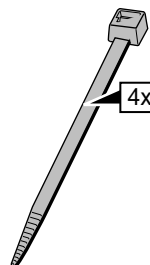
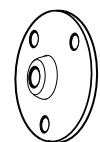
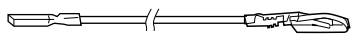

4x

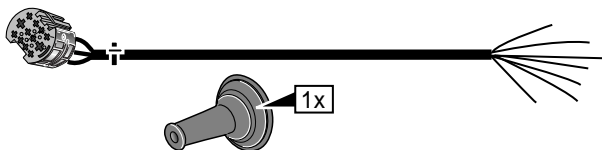

1x



1x

OMEGA

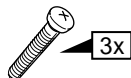

3x



3x



1x

ZAFIRA

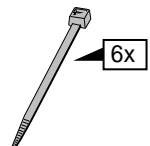

6x

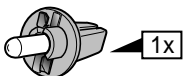

1x

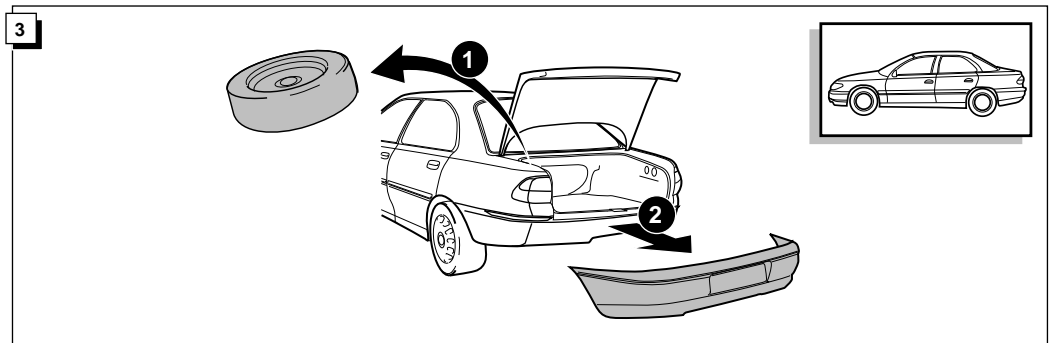
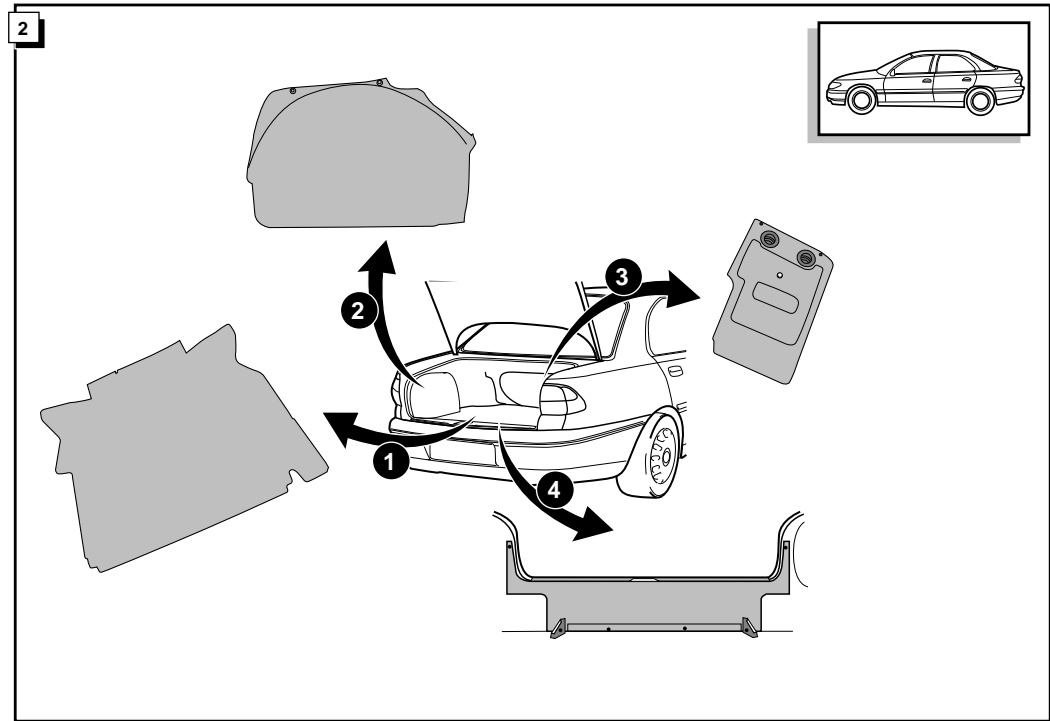
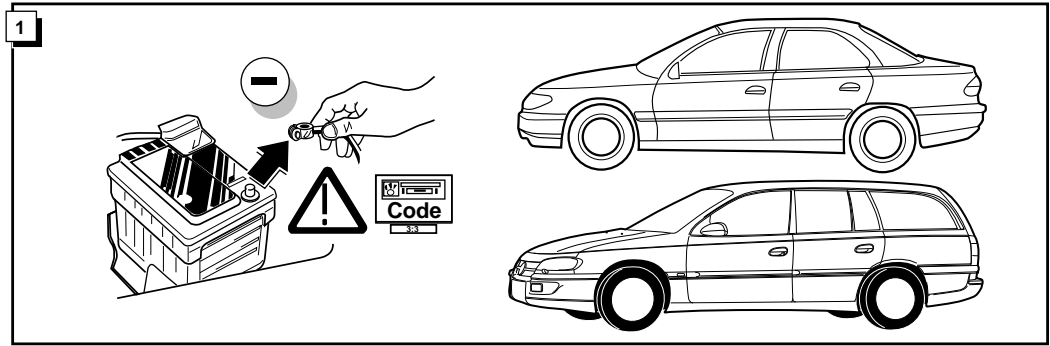

4

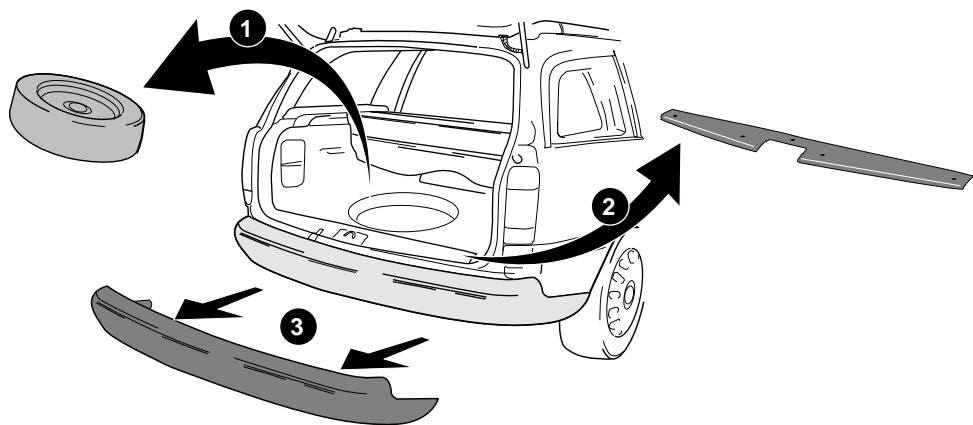
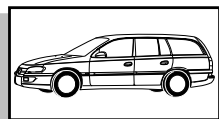

5

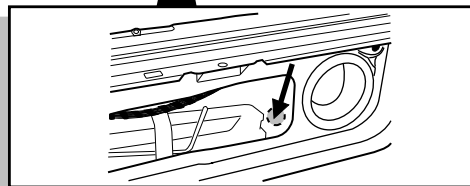
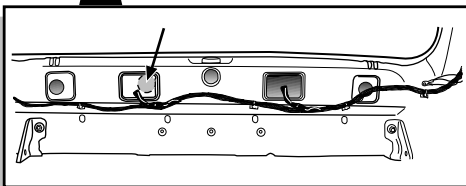
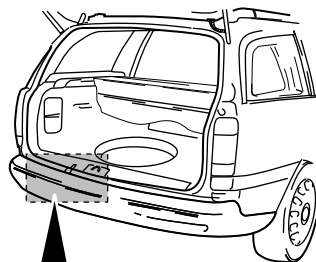
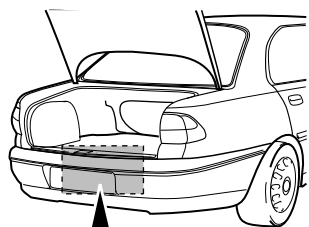
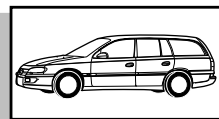
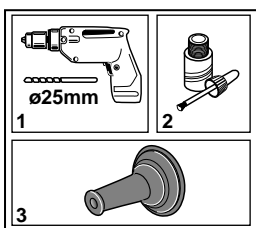
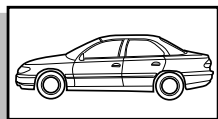

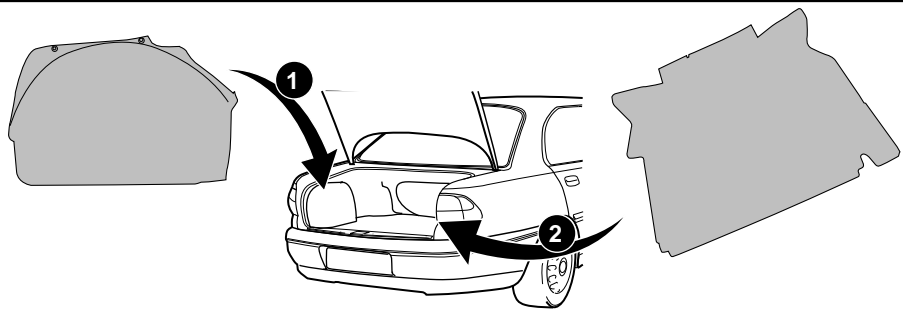

INFO

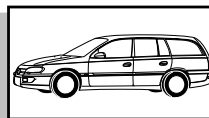
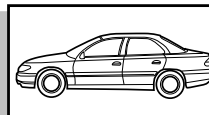

ROUTING

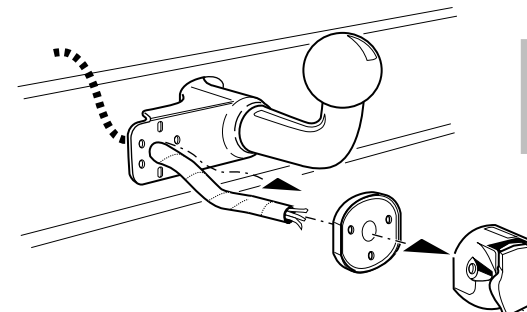
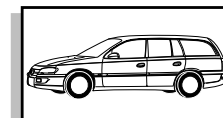
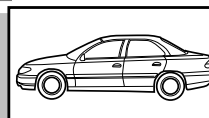
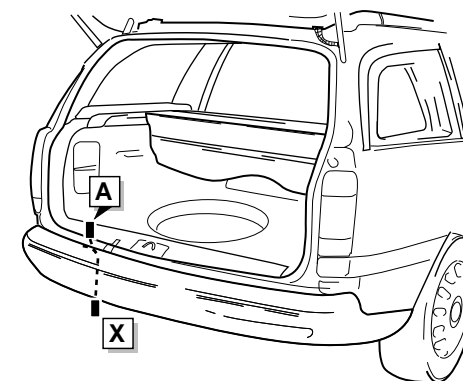
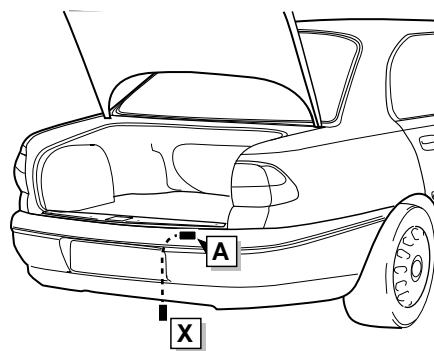
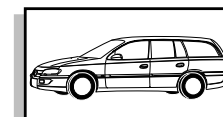
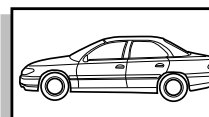

DIN/ISO 1724		D	F	GB	NL
	1/L	gelb	jaune	yellow	geel
	2	blau	bleu	blue	blauw
	3/31	weiß	blanc	white	wit
	4/R	grün	vert	green	groen
	5/58-R	braun	marron	brown	bruin
	6/54	rot	rouge	red	rood
	7/58-L	schwarz	noir	black	zwart
	8/58-b	grau	gris	grey	grijs

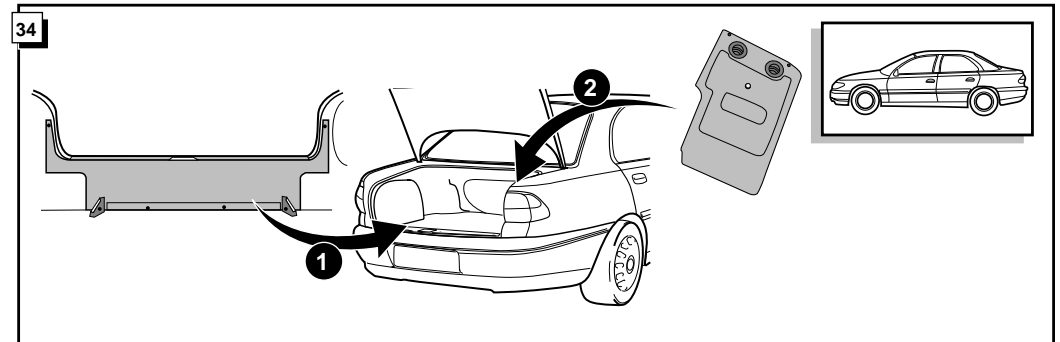
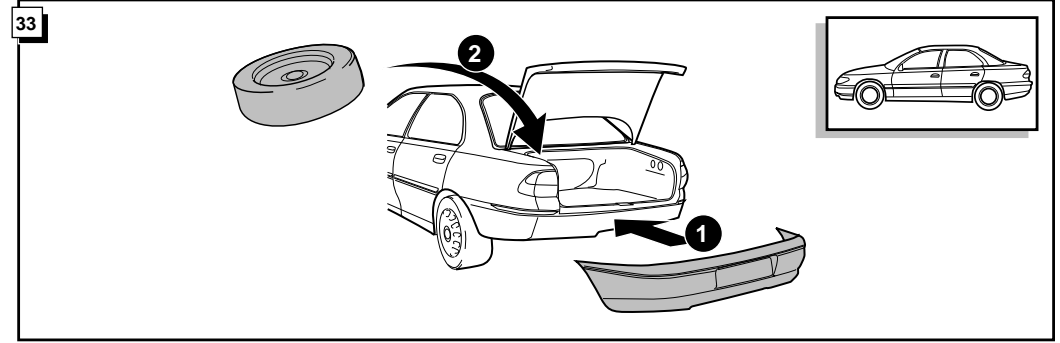
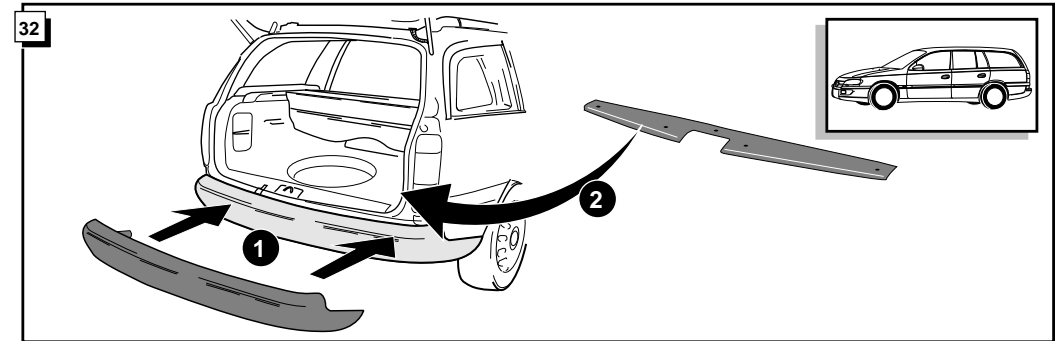
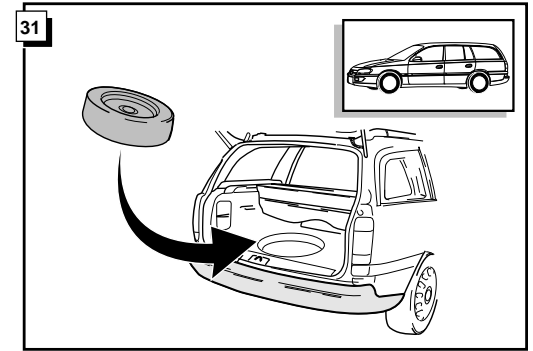
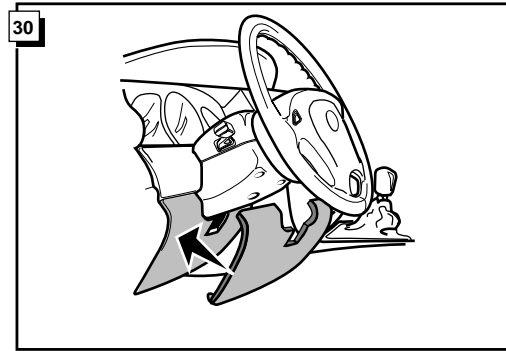
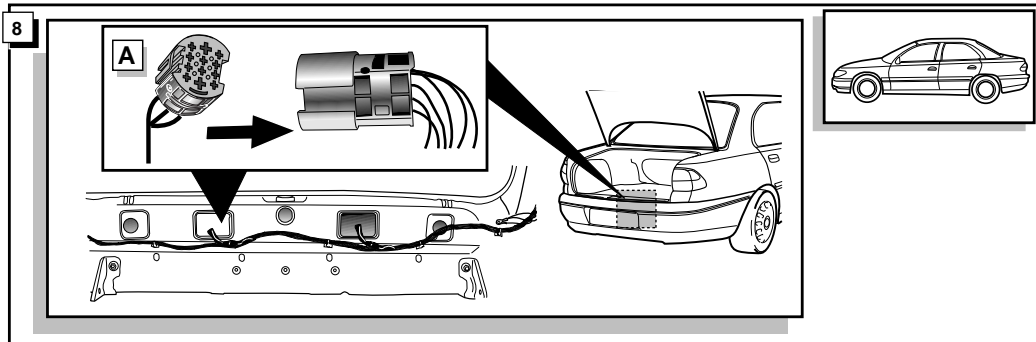
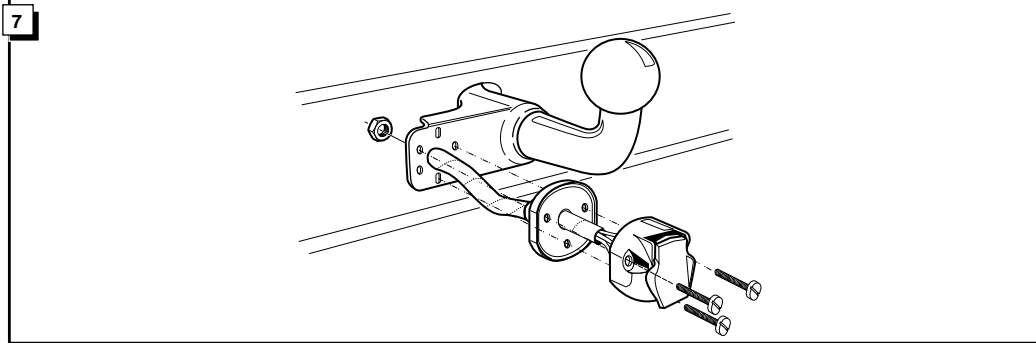

**INFO**

Die Kontrollleuchte blinkt, wenn beim angeschlossenen Anhänger die Blinker (3x21W) oder Warnblinkanlage (6x21W) eingeschaltet sind.

Le deuxième témoin de contrôle clignote lorsque les feux de détresses (6X21W) et les clignotants (3X21W) du véhicule sont allumés alors que la caravane/remorque est accouplée au véhicule.

By switching on flashers with the trailer connected (3x21W) or the warning lights (6x21W), the 2nd direction indicator light will flash.

Het controle-lampje knippert wanneer bij aangesloten aanhanger de knipperlichten (3x21W) of waarschuwingslichten (6x21W) ingeschakeld zijn.

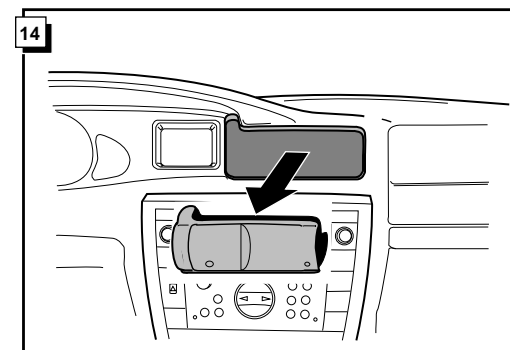
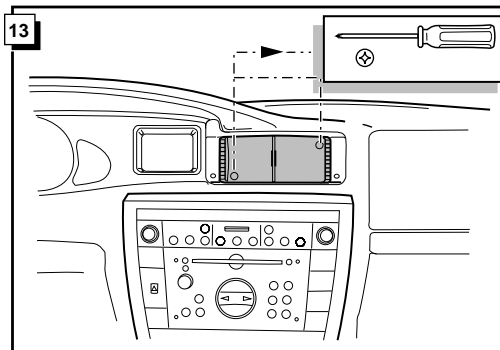
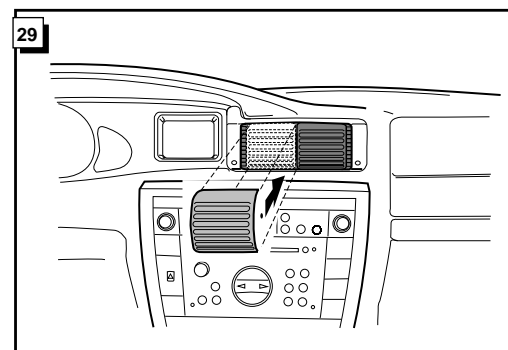
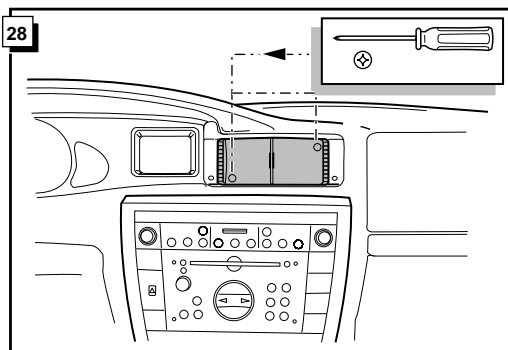
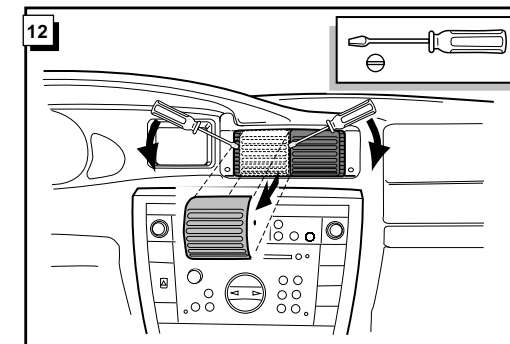
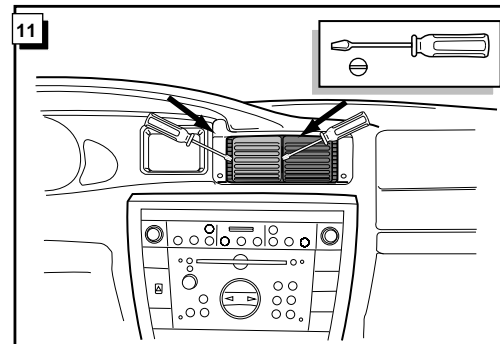
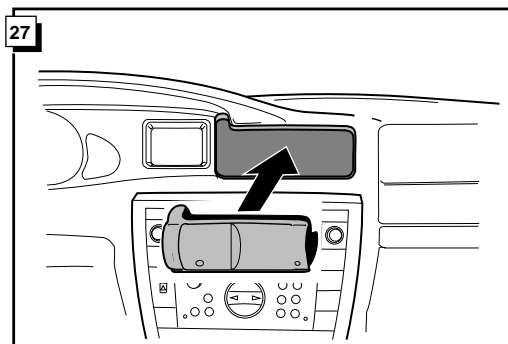
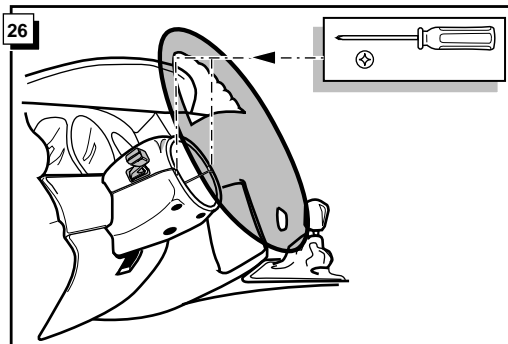
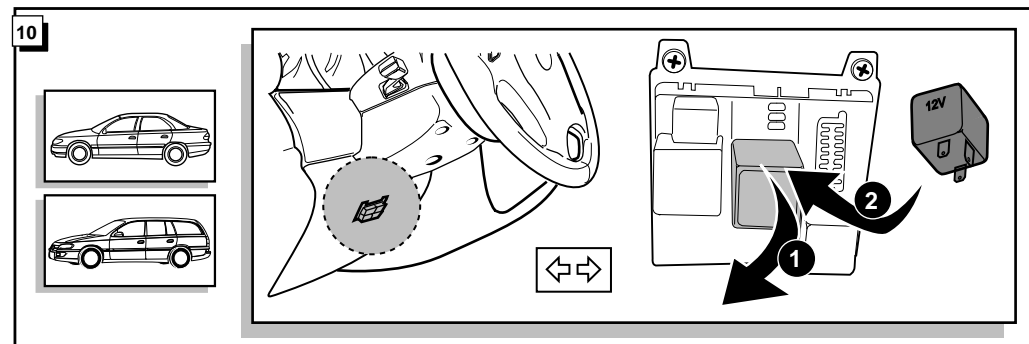
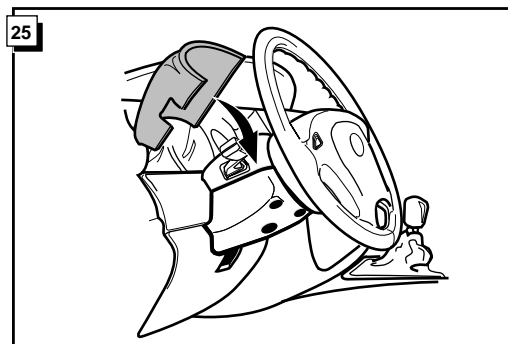
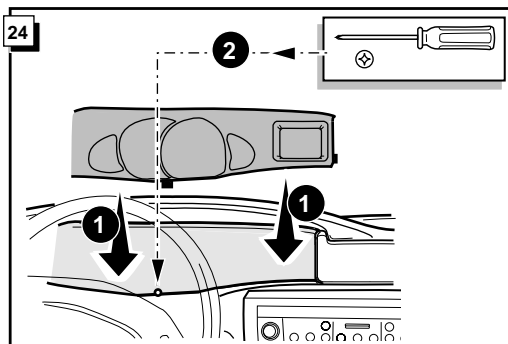
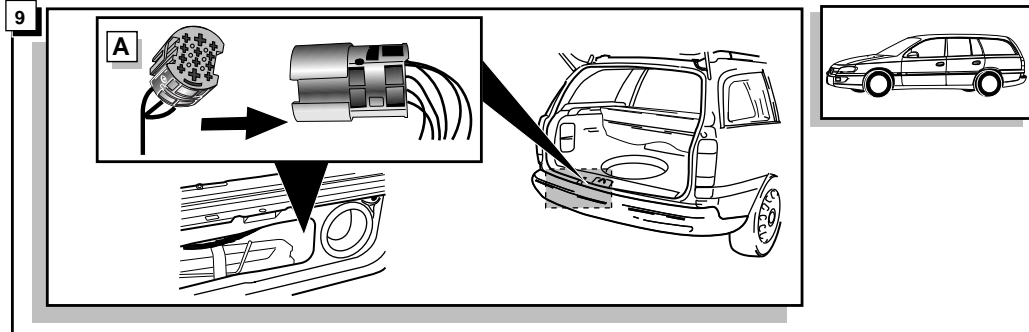

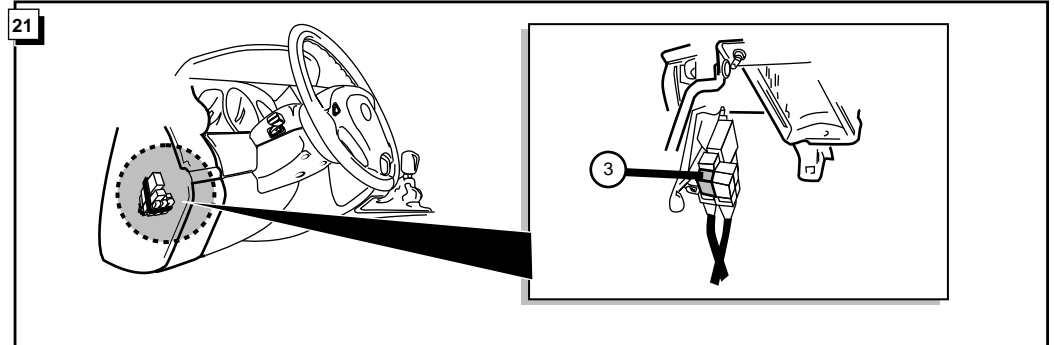
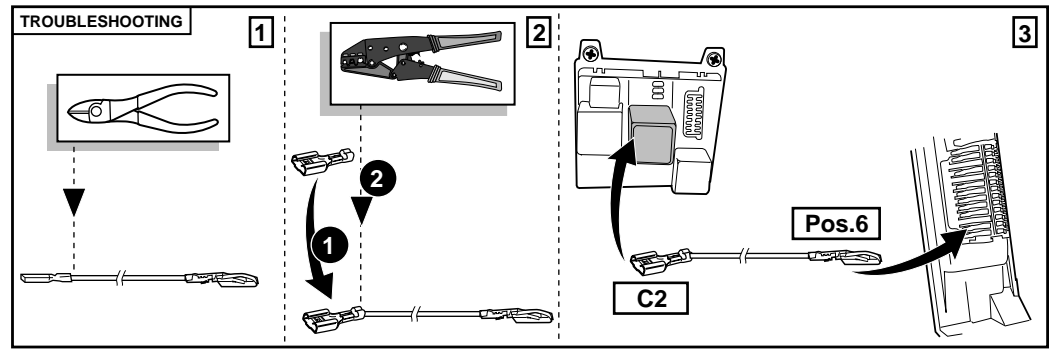
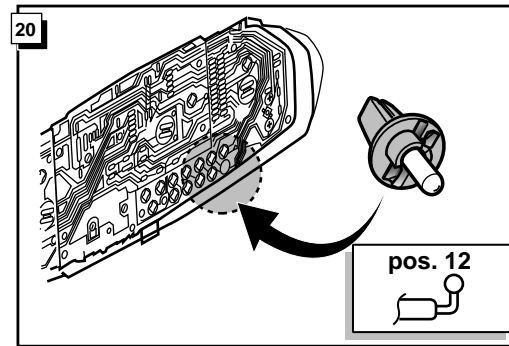
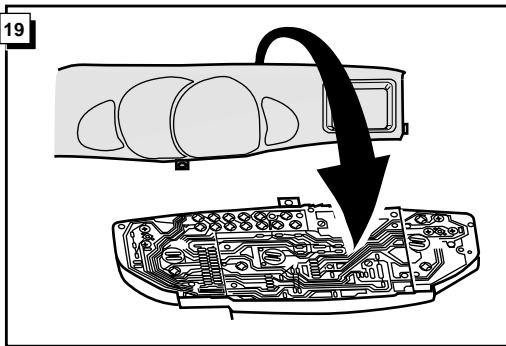
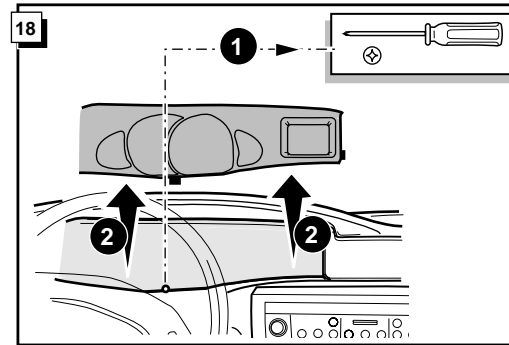
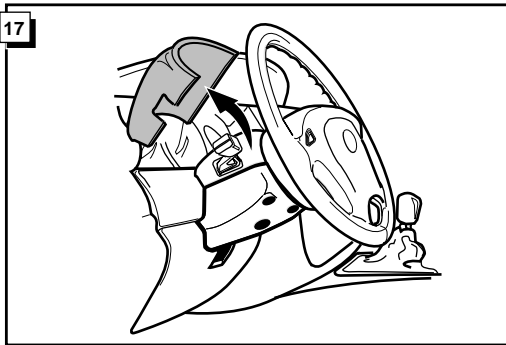
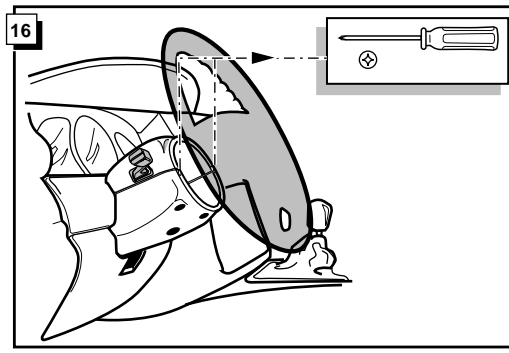
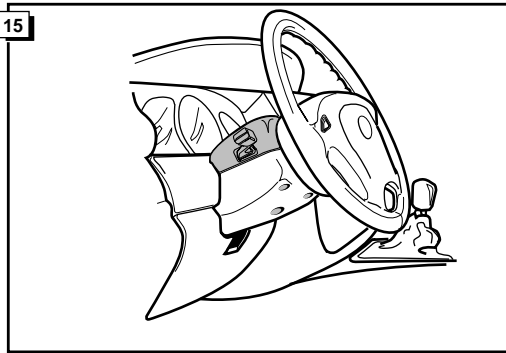





**INFO** Falls die Bremsleuchten des Anhängers nicht funktionieren, müssen Sie das beiliegende Dummy-Relais montieren. Wenn Sie die Bremsleuchten des Anhängers Kontrollieren möchten, so Können sie das original Opel relais bei ihrem Händler bestellen und montieren. Dieses wird das Funktionieren der Bremsleuchten des Anhängers Kontrollieren.

Quand les feux de stop de la remorque ne fonctionnent pas, vous devez monter le relais dummy livré. Quand vous devez contrôler ou les feux de stop de la remorque fonctionnent.

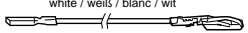
When the brake lights of the trailer do not operate, you will have to mount the supplied dummy relay. If you want to check the brake lights of the trailer, you can also order the original Opel relay, and mount it. This relay will check the functioning of the brake lights of the trailer.

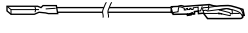
Indien de remlichten van de aanhanger niet functioneren, monteer het meegeleverde dummy-relais. Wanneer u de remlichten van het getrokken voertuig wilt controleren, dan kunt u ook het originele Opel relais bestellen bij de dealer, en monteren. Dit relais controleert dan het functioneren van de remlichten van de aanhanger.

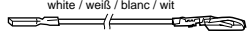
TROUBLESHOOTING	C2	Pos. 6	Action
● Besetzt / Occupé Occupied / Bezet	●	●	Montiere: Montez: Fit: Monteer: 
□ Frei / Libre Clear / Vrij	Zuerst freimachen Libérer Disconnect first Eerst vrij maken	□	Montiere: Montez: Fit: Monteer: white / weiß / blanc / wit  + 
	□	● Zuerst freimachen Libérer Disconnect first Eerst vrij maken	Montiere: Montez: Fit: Monteer: white / weiß / blanc / wit  + 
	□	□	Montiere: Montez: Fit: Monteer: white / weiß / blanc / wit  + 