

Einbauanleitung Elektrosatz
Anhängervorrichtung mit 13-P Steckdose
lt. DIN/ISO Norm 11446

Instructions de montage du faisceau
électrique pour crochet d'attelage
conforme à la norme
DIN/ISO 11446 prise 13-P

Fitting instructions electric wiringkit
towbar with 13-P socket up to
DIN/ISO norm 11446

Montage-handleiding elektrokabelset voor
trekhaak met 13-P contactdoos
vlgs. DIN/ISO norm 11446

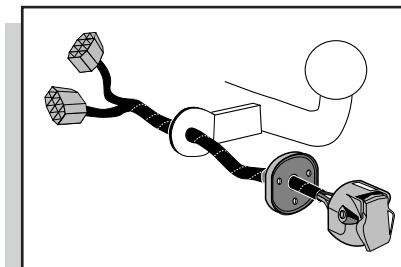

MERCEDES W210/S210 1995-
CLK C208 1997-

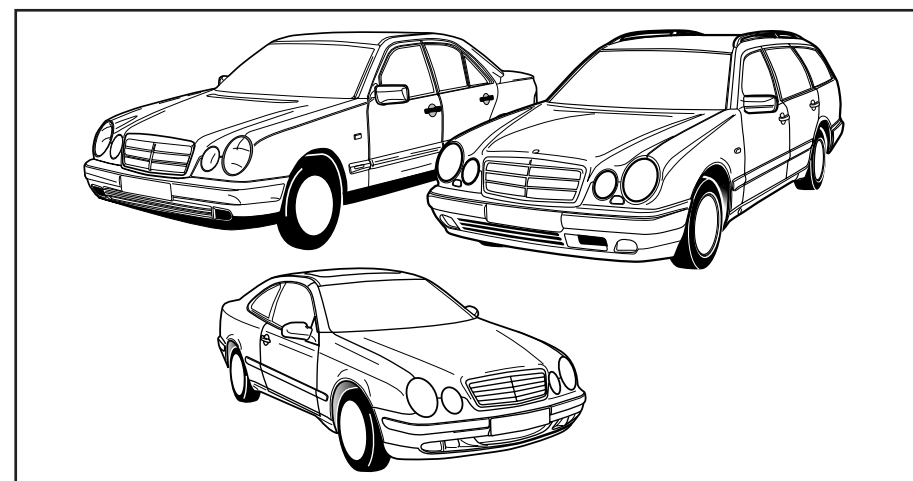

Bestel Nr.: MB-926-KL

* Teilliste

* Liste de pieces

* Part list

* Onderdelenlijst

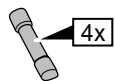
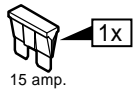
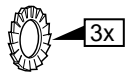
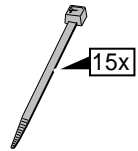
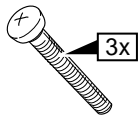
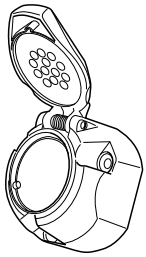
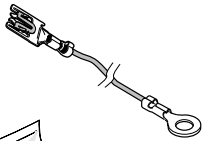
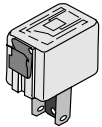
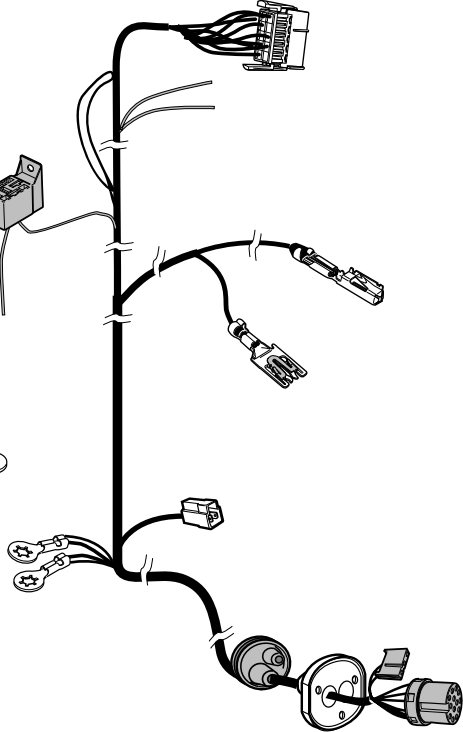
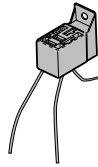
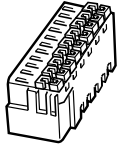
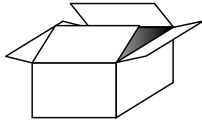

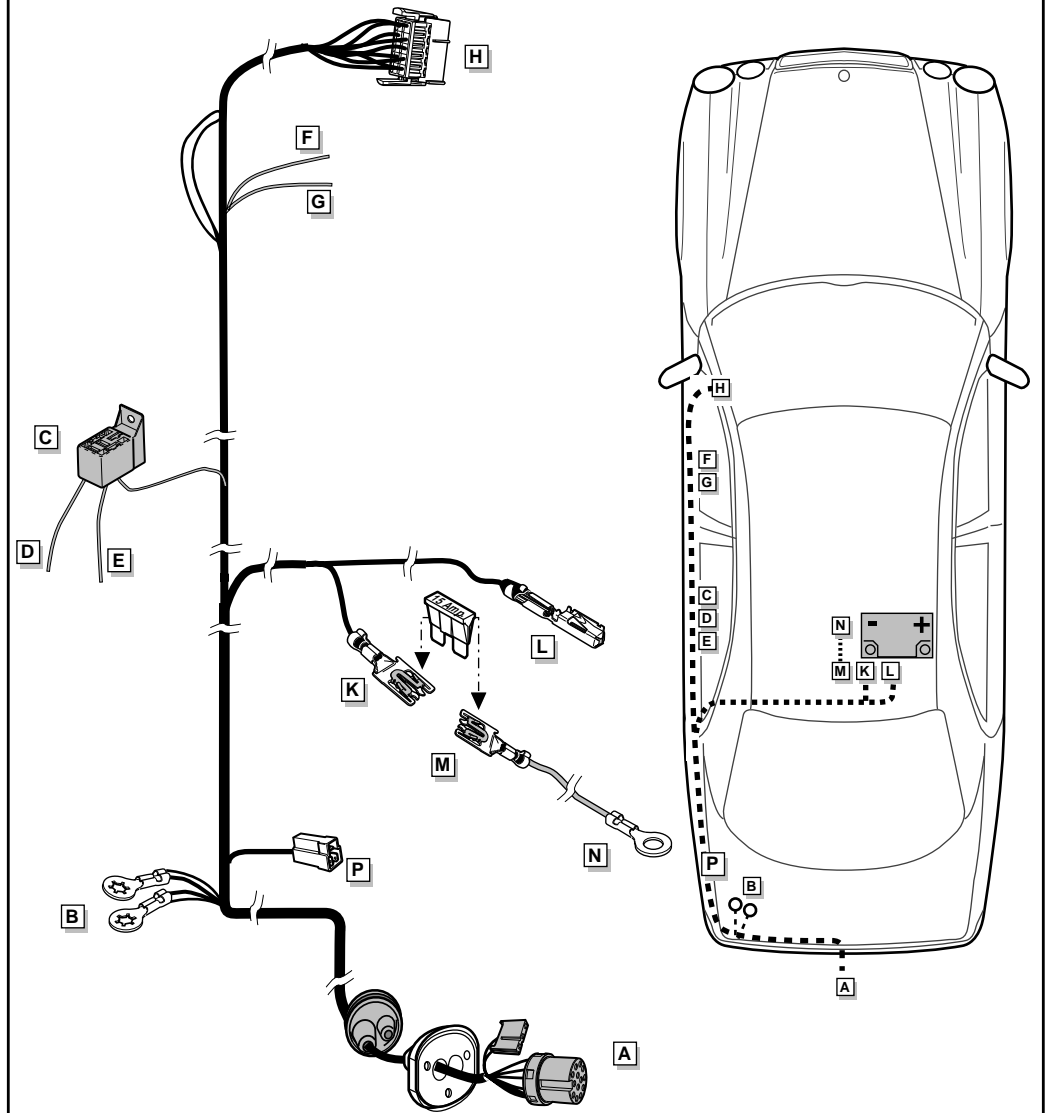

INFO & ROUTING C208

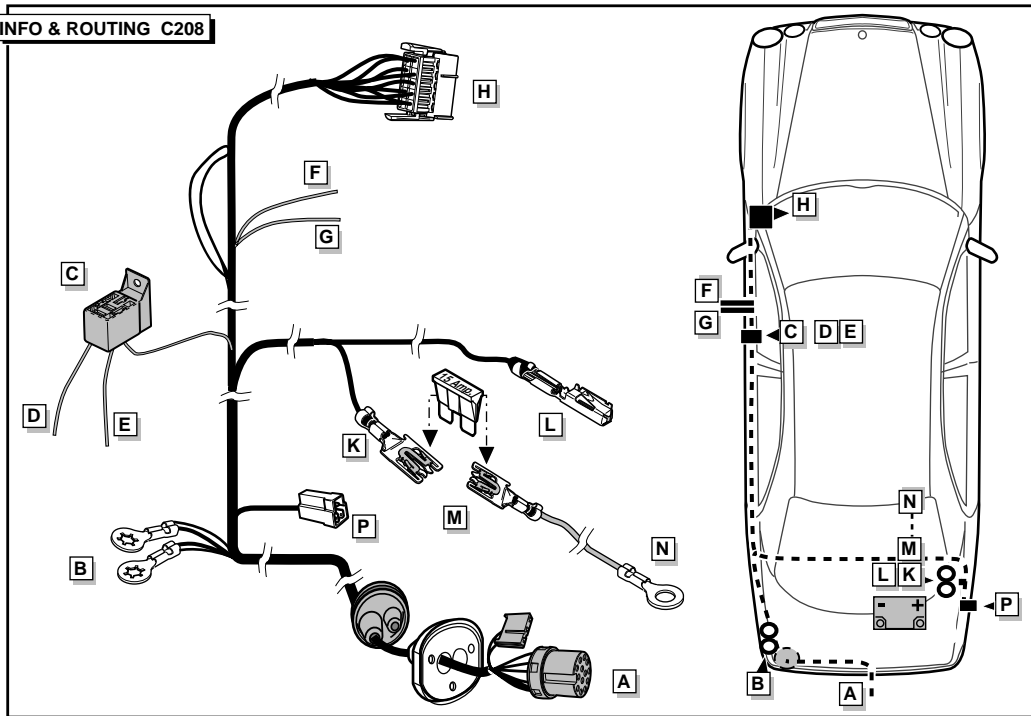

50 C208

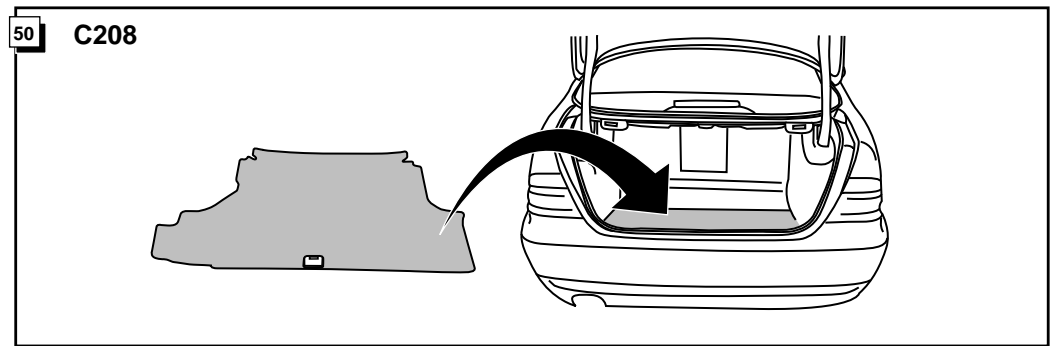

1 W210

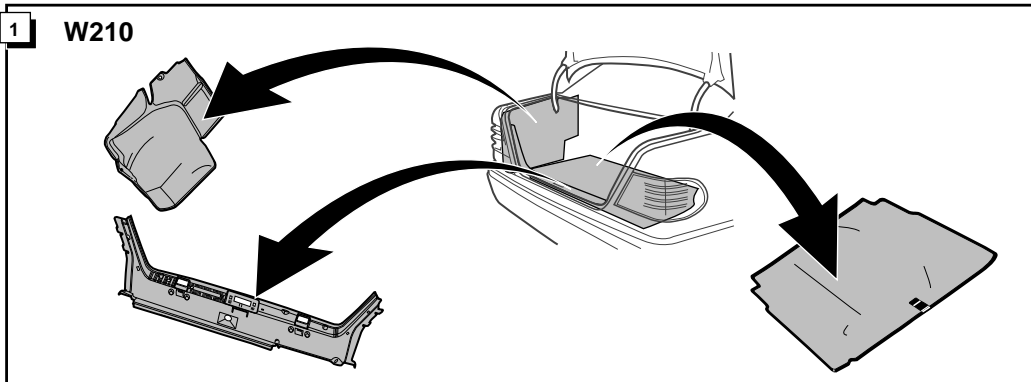

S210

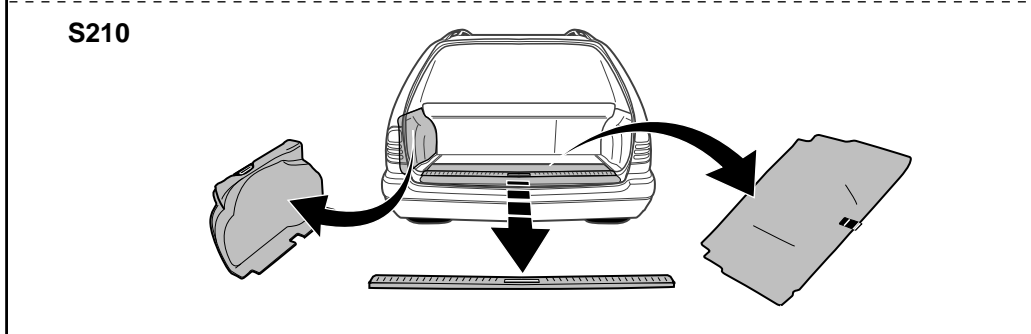

46 W210+S210

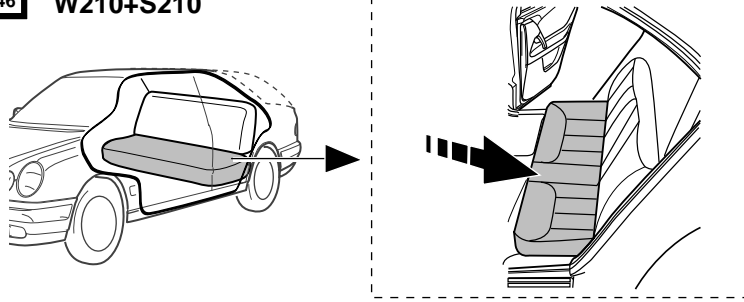

2 C208

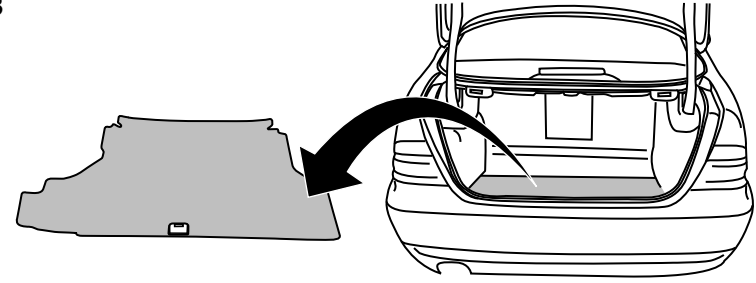

47 W210

S210

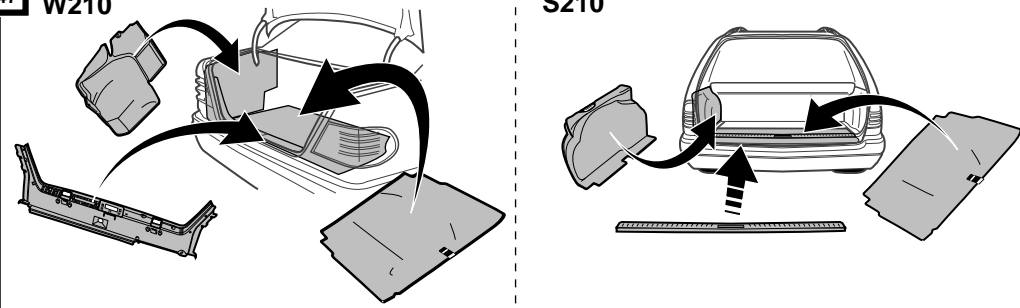

3 C208

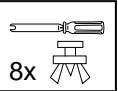
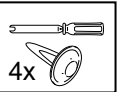
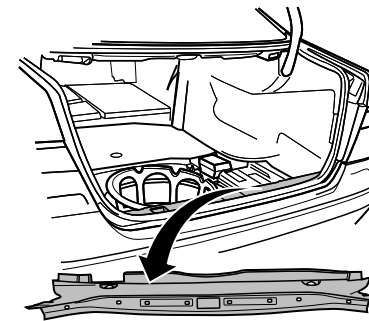

48 C208

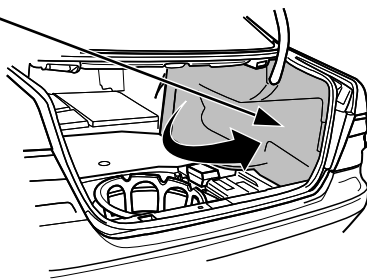
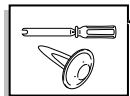

4 C208

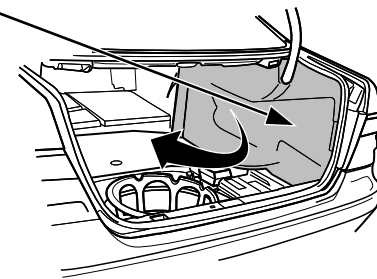
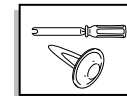

49 C208

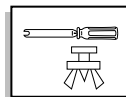
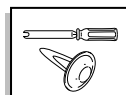
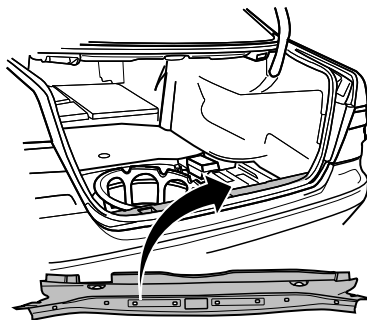

5 W210+S210

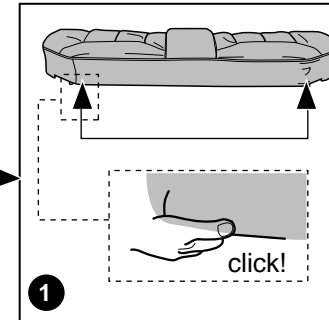
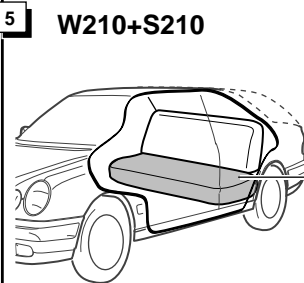

1

click!

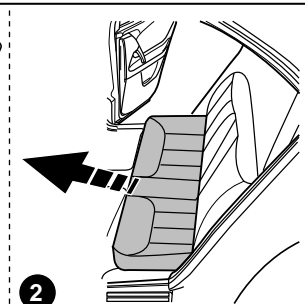

2

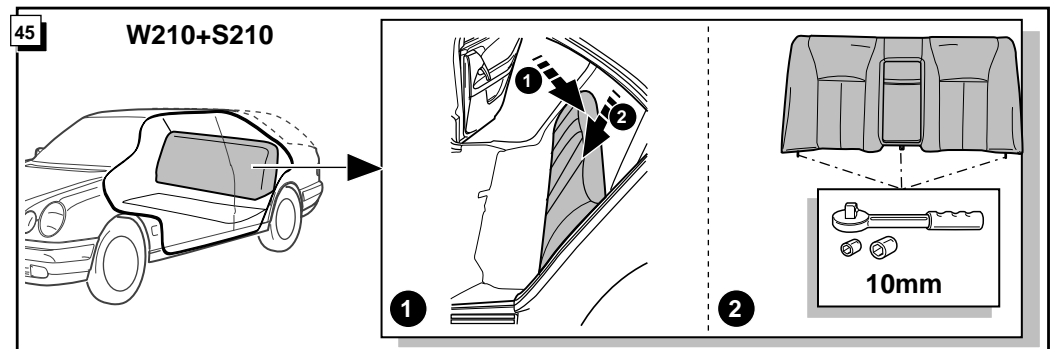
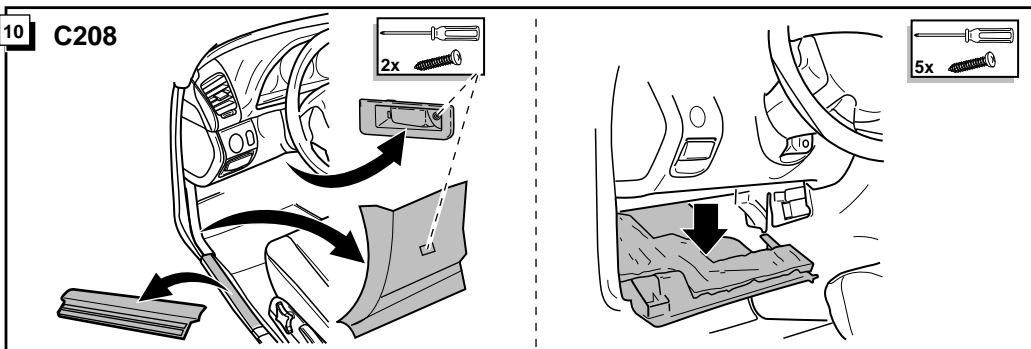
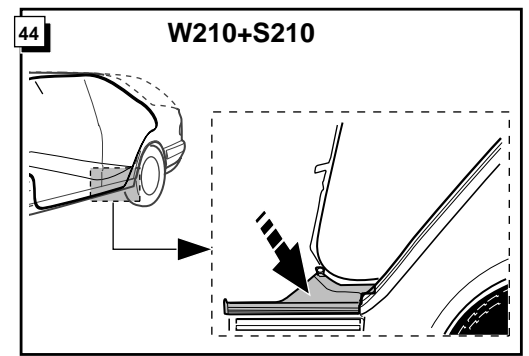
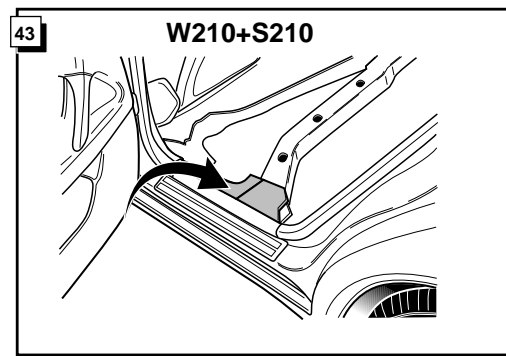
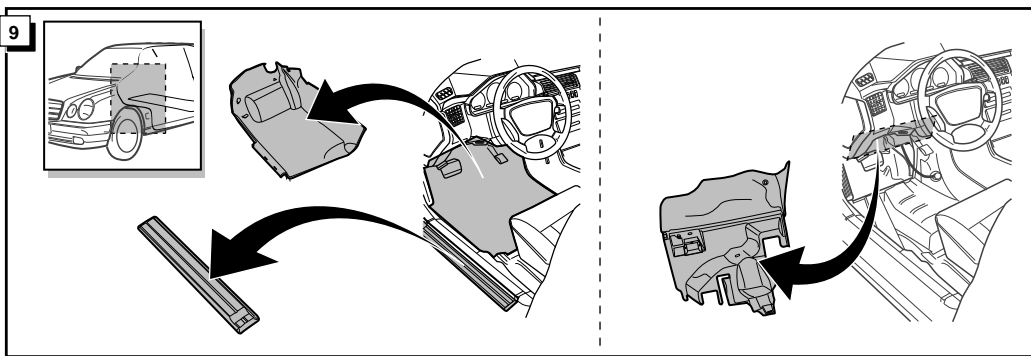
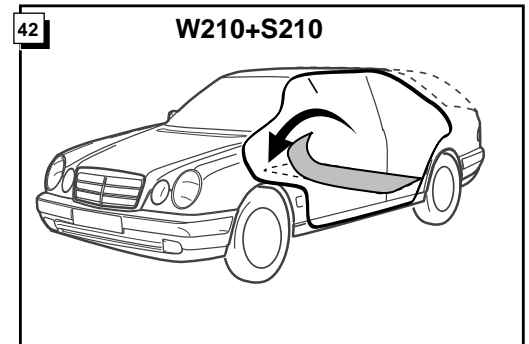
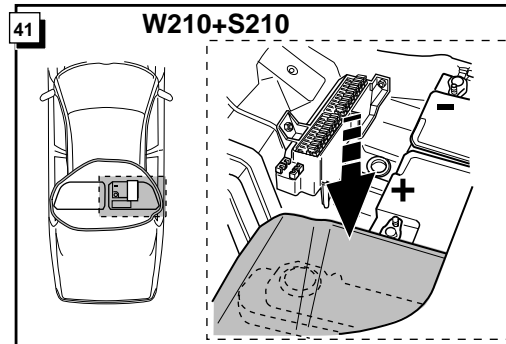
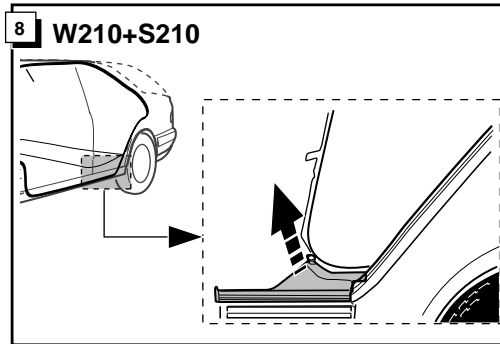
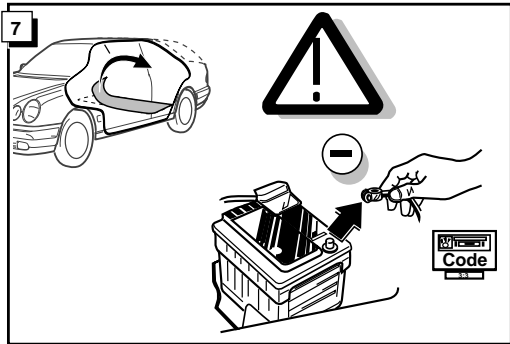
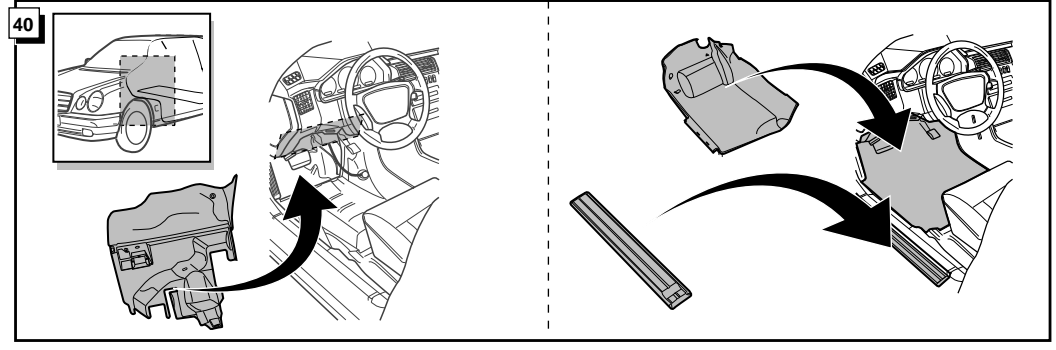
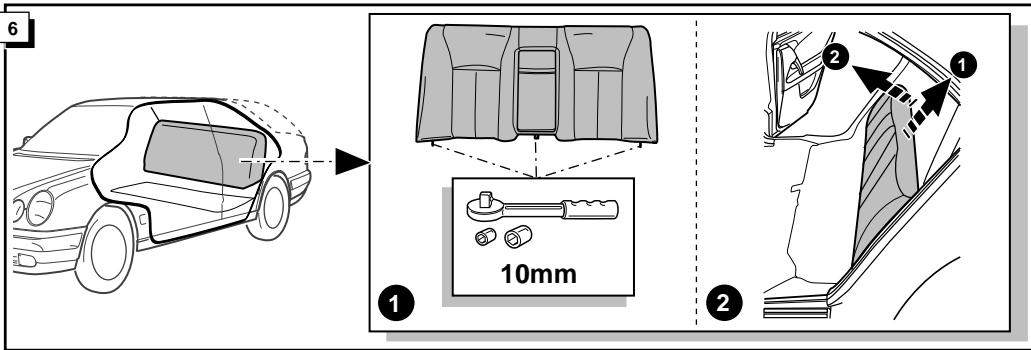

37

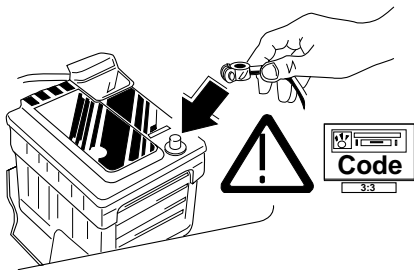

38

FUNKTIONEN KONTROLLIEREN !
CONTRÔLER LES FONCTIONS !
CHECK FUNCTIONS !
CONTROLEER FUNCTIES !

INFO Anschluß Steckdose / Connection de la prise / Socket connection / Contactdoos aansluiting

DIN/ISO 11446		(D)	(F)	(GB)	(NL)
	1/L	schwarz/weiß	noir/blanc	black/white	zwart/wit
	2	grau/grün	gris/vert	grey/green	grijs/groen
	3/31	braun	marron	brown	bruin
	4/R	schwarz/grün	noir/vert	black/green	zwart/groen
	5/58-R	grau/rot	gris/rouge	grey/red	grijs/rood
	6/54	schwarz/rot	noir/rouge	black/red	zwart/rood
	7/58-L	grau/schwarz	gris/noir	grey/black	grijs/zwart
	8	grau/gelb	gris/jaune	gris/yellow	grijs/geel
	9	rot/blau/grau	rouge/bleu/gris	red/blue/grey	rood/blauw/grijs
	10	rot	rouge	red	rood
	11	braun	marron	brown	bruin
	12	rot/blau	rouge/bleu	red/blue	rood/blauw
	13	braun	marron	brown	bruin

39

*Das im Fahrzeug anwesende Relais funktioniert normal wie ein 2/4 x 21W Relais, aber wenn die Anhänger angeschlossen ist, funktioniert das Relais wie ein 2+1/6 x 21W Relais.

*Le relay origine fonctionnez comme si un relay de 2/4x21W. Avec le caravane connecter le relay fonctions comme si un relay 2+1/6x21W.

*The original blinkerrelay functions normally as a 2/4x21W relay. Only if the trailer/caravan is connected it functions as a 2+1/6x21W relay.

*Het bestaande knipperrelais functioneert als een 2/4x21W relais. Als de aanhanger aangesloten is functioneert deze als een 2+1/6x21W relais.

11

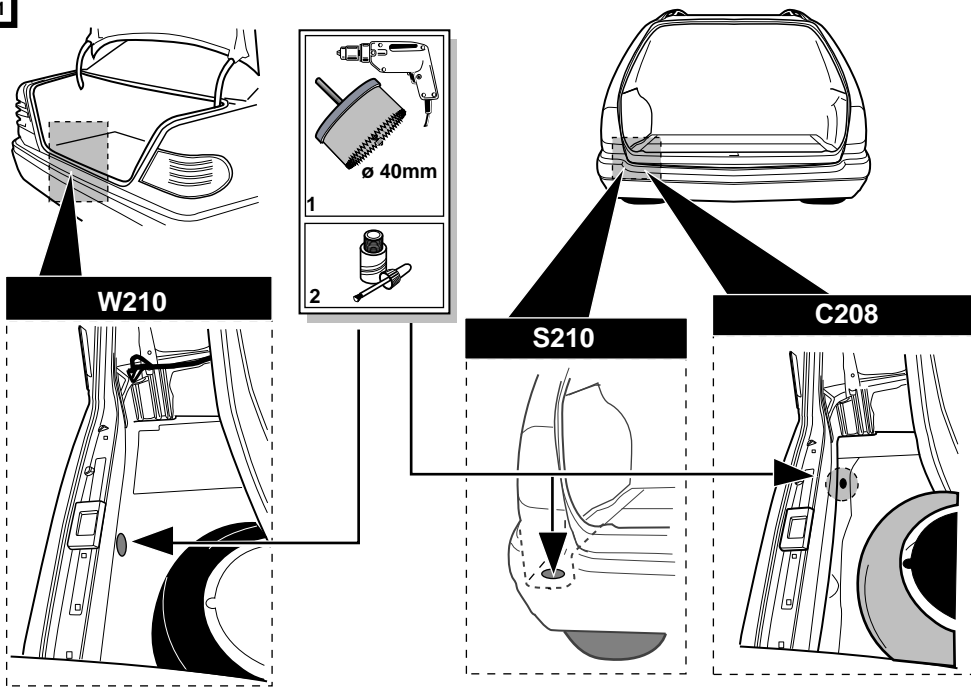

12

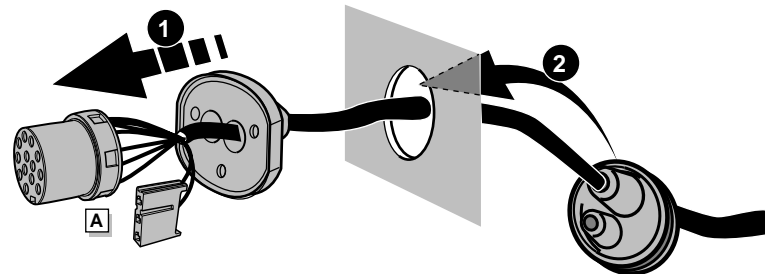

13

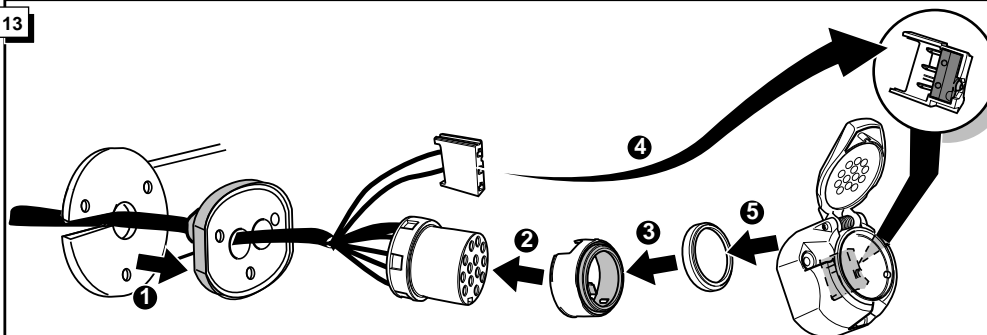

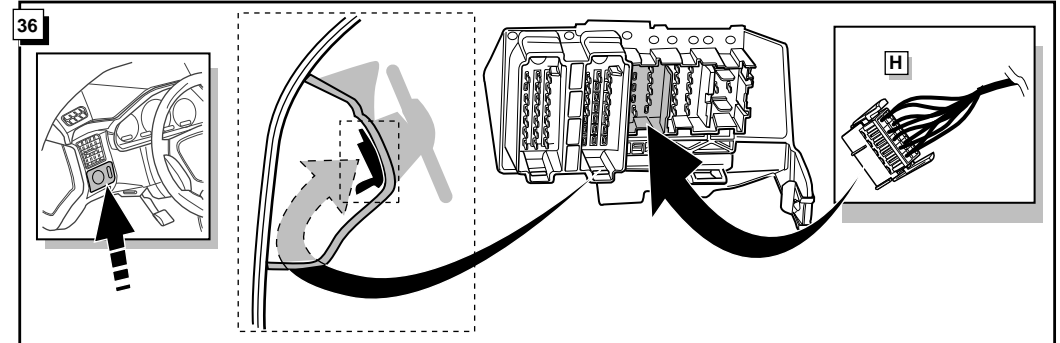
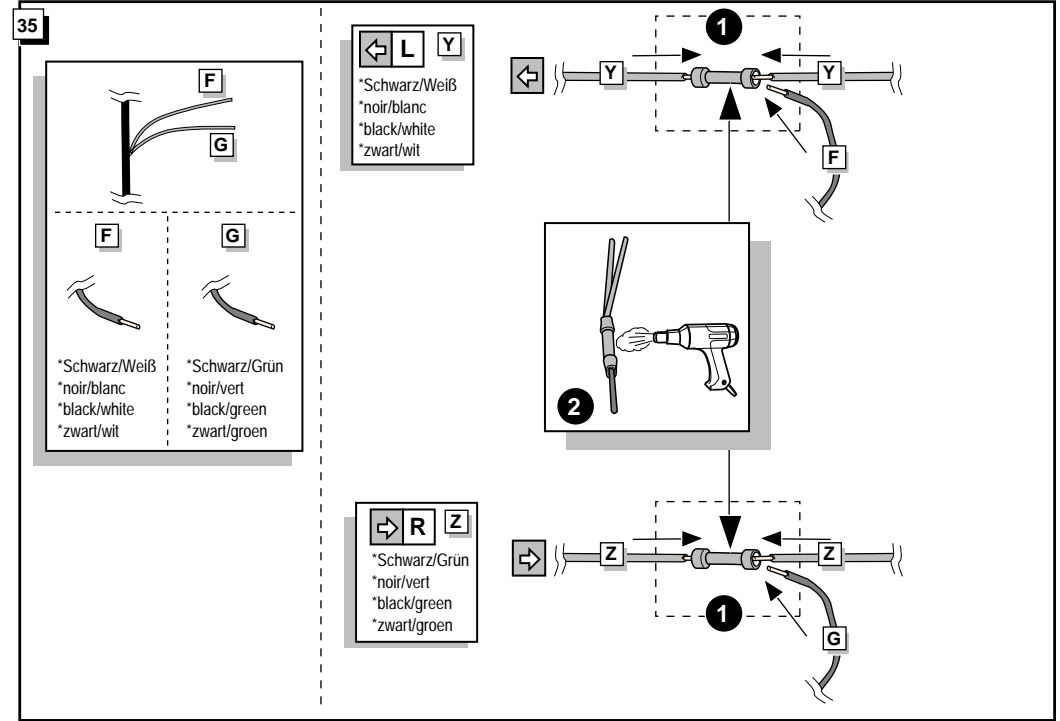
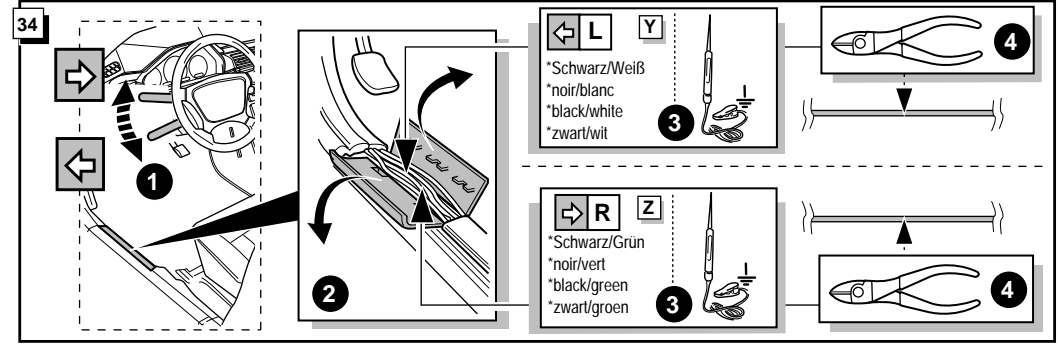
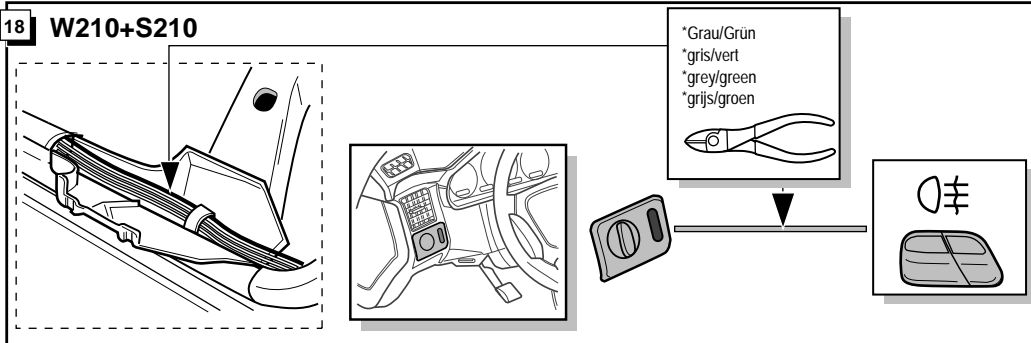
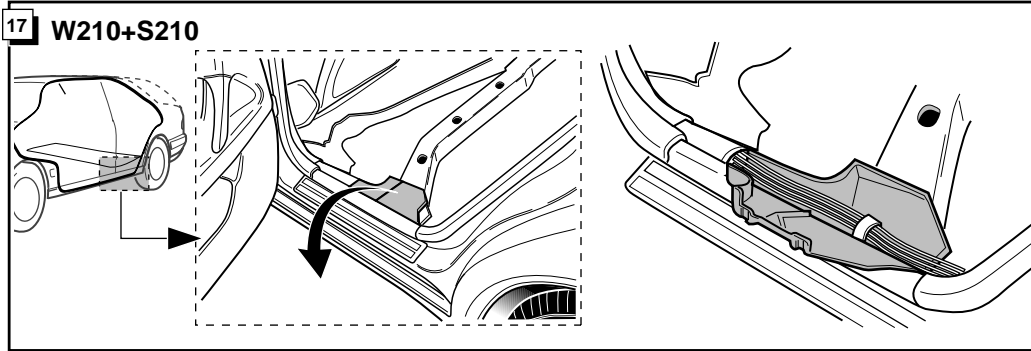
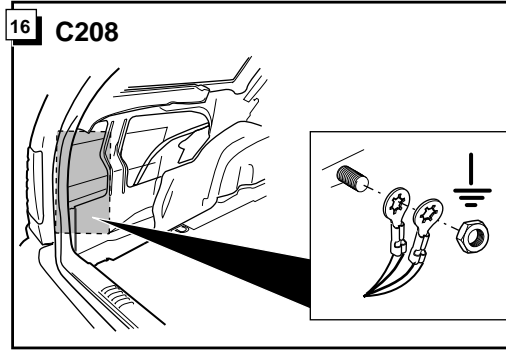
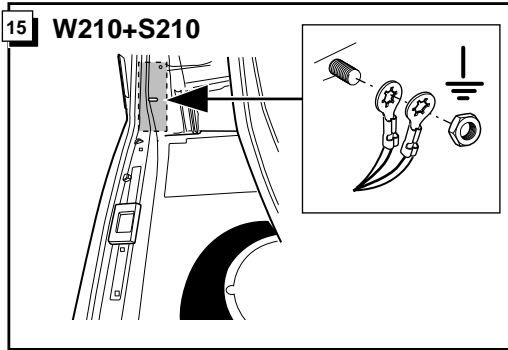
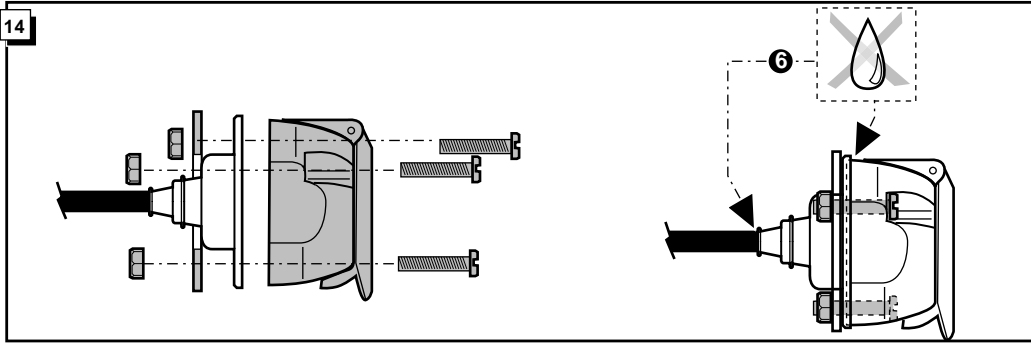

32 C208

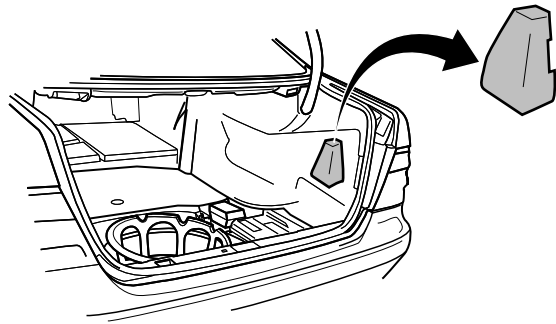

19 C208

*Grau/Grün
*gris/vert
*grey/green
*grijs/groen

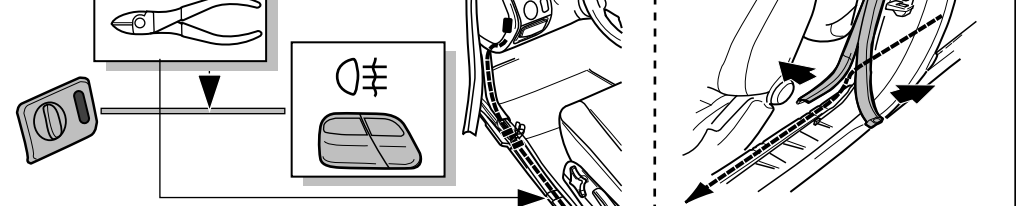

33

W210+S210

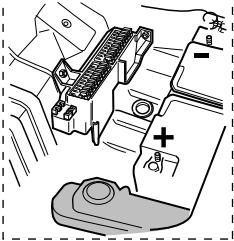

C208

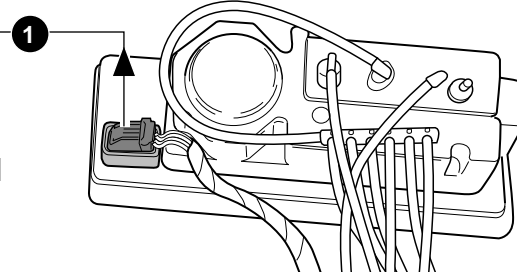
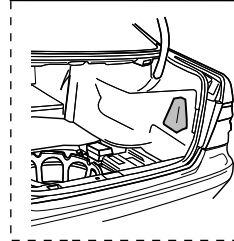

- * **Q** kann 4-, 12- oder 18-polige sein.
Sehe die Tabelle für die richtige Position.
- * **Q** peut être 4-,12- ou 18-pôles.
Voir le table pour le position juste.
- * **Q** can be 4-, 12- or 18-pole.
See table for the right position.
- * **Q** kan 4-, 12- of 18-polig zijn.
Voor de juiste positie zie tabel.

Poles Q	Position L
4	2
12	2
18	15

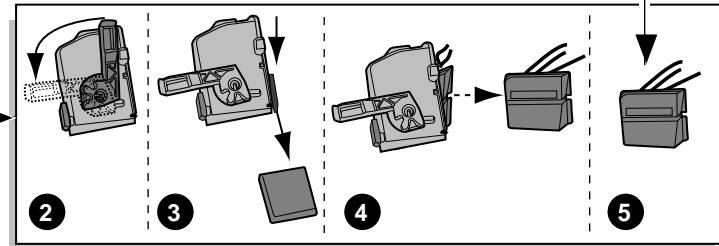
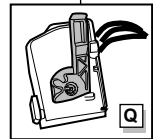
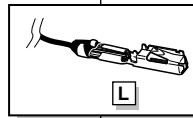

20

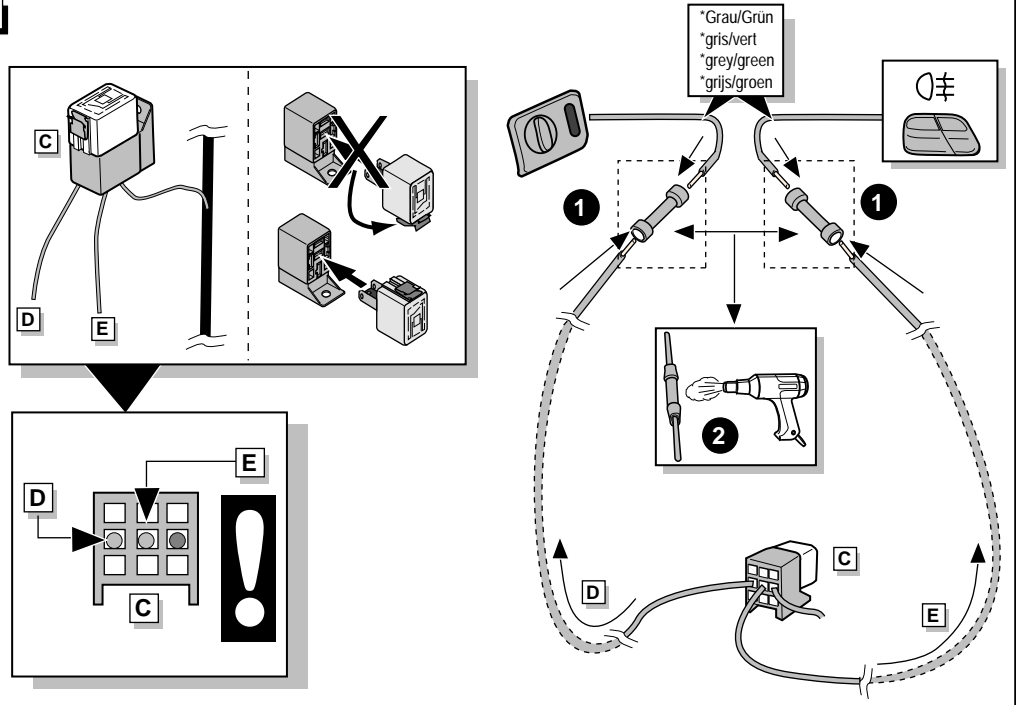

21 W210+S210

